

TECHNICAL
CATALOGUE
RESIDENTIAL
AIR CONDITIONING
2021-2022

- WALL MOUNTED AC
- MULTI VARIABLE SERIES
- HIGH POWER MULTI SYSTEM
- UNI SPLIT SERIES
- HIGH STATIC PRESSURE DUCT UNIT
- PORTABLE DEVICES



SINCLAIR

AIR CONDITIONING

CONTENT

SPECTRUM+ SERIES	3
TERREL SERIES	6
KEYON SERIES	9
RAY SERIES	12
CONSOLE SERIES	16
MULTI VARIABLE SERIES	19
HIGH POWER MULTI SYSTEM SERIES	37
UNI SPLIT SERIES	44
HIGH STATIC PRESSURE DUCT UNIT	61
TOWER SERIES	63
WINDOW SERIES	64
CAMPER TRAILER	65
BOAT SERIES	66
LOCAL AIR CONDITIONERS	68
DEHUMIDIFIERS	69
AIR PURIFIER	70
COMMUNICATION MODULE SCMI-01.4	71
HEALTH FILTERS FOR WALL MOUNTED UNITS	74
WIRED CONTROLLERS	75
CENTRAL CONTROLLERS	77
OTHER ACCESSORY	79
SYSTEM ERROR DIAGNOSIS	81
ERROR CODES	82

WALL MOUNTED SPLIT AIR CONDITIONERS

SPECTRUM PLUS SERIES

MODEL			ASH-09BIS2/W	ASH-13BIS2/W	ASH-18BIS2/W	ASH-24BIS2/W	
Capacity cooling/heating 1)	Nominal (min-max)	kW	2,7 (0,7-5,0) / 3,5 (0,7-5,5)	3,6 (0,9-5,0) / 4,2 (0,9-7,2)	5,3 (1,2-7,2) / 6,2 (1,2-9,2)	7,1 (2,0-9,0) / 7,1 (2,0-9,5)	
Power supply		Hz / V	1~ / 50 / 220-240	1~ / 50 / 220-240	1~ / 50 / 220-240	1~ / 50 / 220-240	
Power supply		-	outdoor	outdoor	outdoor	outdoor	
Power input cooling/heating 1)		W	550 / 745	840 / 950	1180 / 1450	1850 / 1750	
Maximal power input 2)		W	2400	2600	3200	3800	
Power current cooling/heating		A	3,6 / 4,7	5,1 / 5,7	5,9 / 5,9	11,0 / 11,0	
Maximal power current 2)		A	8,0	8,2	13,0	16,4	
Energy class cooling 3)		-	A+++	A+++	A++	A++	
Pdesign cooling		kW	2,7	3,5	5,3	7,0	
SEER		-	8,5	8,5	7,5	6,5	
Annual power consumption		kWh / annum	111	144	247	377	
Energy class heating 3)	Aver./Warm./Cool.	-	A+++ / A+++ / A	A+++ / A+++ / A+	A+ / A+++ / A	A+ / A+++ / A	
Pdesign heating	Average climate	kW	3,5	3,5	5,9	7,0	
SCOP	Average climate	-	5,1	5,1	4,4	4,1	
Annual power consumption	Average climate	kWh / annum	961	961	1877	2390	
Airflow of ID	SH/MH/H/ML/ML/SL	m ³ / h	800 / 730 / 680 / 630 / 580 / 450 / 350	800 / 730 / 680 / 630 / 580 / 450 / 350	1200 / 1150 / 1050 / 950 / 850 / 780 / 600	1200 / 1050 / 950 / 900 / 850 / 800 / 750	
Airflow of OD	H	m ³ / h	2400	2400	4000	4000	
Sound pressure level of ID at 1m 4)	SH/MH/H/ML/ML/SL	dB(A)	44 / 43 / 38 / 36 / 31 / 24 / 22	44 / 43 / 38 / 36 / 31 / 24 / 22	46 / 44 / 42 / 39 / 36 / 34 / 32	50 / 46 / 43 / 41 / 39 / 37 / 35	
Sound pressure level of OD at 1m 4)	H	dB(A)	53	54	56	58	
Sound power of ID 4)	SH/MH/H/ML/ML/SL	dB(A)	58 / 53 / 48 / 46 / 41 / 34 / 32	58 / 53 / 48 / 46 / 41 / 34 / 32	60 / 54 / 52 / 49 / 46 / 44 / 42	64 / 60 / 57 / 55 / 53 / 51 / 49	
Sound power of OD 4)	H	dB(A)	62	62	63	69	
Dehumidifying volume		l / h	0,8	1,4	1,8	2,0	
Refrigerant type/charge		Type / kg / t eq. CO ₂	R32 / 1,00 / 0,67	R32 / 1,00 / 0,67	R32 / 1,50 / 1,01	R32 / 2,00 / 1,35	
Additional refrigerant		g / m	16	16	40	50	
Pipe diameter - liquid side 5)		inch / mm	¼ / 6,0	¼ / 6,0	¼ / 6,0	¼ / 6,0	
Pipe diameter - gas side 5)		inch / mm	¾ / 9,5	¾ / 9,5	¾ / 16,0	¾ / 16	
Max pipe length without additional refrigerant 6)		m	5	5	5	7,5	
Allowed pipe length 7)	min./max.	m	3 / 15	3 / 20	3 / 40	3 / 50	
Max. elevation/ Drop height		m	10	10	20	30	
Dimension of ID	w x h x d	mm	996 x 301 x 225	996 x 301 x 225	1101 x 327 x 249	1101 x 327 x 249	
Dimensions of OD	w x h x d	mm	899 x 596 x 378	899 x 596 x 378	980 x 790 x 427	1003 x 790 x 427	
Package dimension of ID	w x h x d	mm	1060 x 380 x 322	1060 x 380 x 322	1167 x 405 x 354	1167 x 405 x 354	
Package dimensions of OD	w x h x d	mm	948 x 420 x 645	948 x 420 x 645	1083 x 488 x 855	1083 x 488 x 855	
Weight of ID	net / gross	kg	13,0 / 16,0	13,5 / 16,5	16,5 / 20,0	16,5 / 20,0	
Weight of OD	net / gross	kg	44,5 / 47,5	45,5 / 48,5	61,0 / 66,0	65,0 / 70,0	
Set temperature range		°C	16 ~ 30	16 ~ 30	16 ~ 30	16 ~ 30	
Operating temperature range cooling 8)		°C	-18 ~ 52	-18 ~ 52	-18 ~ 52	-18 ~ 52	
Operating temperature range heating 8)		°C	-30 ~ 24	-30 ~ 24	-30 ~ 24	-30 ~ 24	
ADDITIONAL TECHNICAL INFORMATION							
Screw holes distance of OD	w x d	mm	550 x 354	550 x 354	610 x 395	610 x 395	
Communication cable		mm ²	4 x 0,75 (5m included)				
Recommended power cable		mm ²	3 x 1,5	3 x 1,5	3 x 2,5	3 x 4,0	
Recommended air switch		A	13	13	16	20	
EQUIPMENT							
Plasma generator	indoor		✓	✓	✓	✓	
Wifi module			✓	✓	✓	✓	
Drain pump			-	-	-	-	
Max. lift (from bottom of ID unit)		mm	-	-	-	-	
Dry contact (ON/OFF)			✓	✓	✓	✓	
Alarm contact			-	-	-	-	
Left-right guide louvres			✓	✓	✓	✓	
Throttling method	outdoor		EXV	EXV	EXV	EXV	
Bottom chassis heater			Heating belt	Heating belt	Heating belt	Heating belt	
Crankcase heater			Preheating	Preheating	Preheating	Preheating	
Bottom plugs for OD			✓	✓	✓	✓	
Drain pipe connector			✓	✓	✓	✓	
STANDARD ACCESSORIES							
Standard health filter			SAF-OPWC4, SAF-OPWS4				
Remote controller (IR)			YAG1FB2	YAG1FB2	YAG1FB2	YAG1FB2	
Wired controller			-	-	-	-	
OPTIONAL ACCESSORIES							
Optional health filters			SAF-OPWA4, SAF-OPWB4, SAF-OPWK4, SAF-OPWM4, SAF-OPWP4				
Wired controller			SWC-02, XK19	SWC-02, XK19	SWC-02, XK19	SWC-02, XK19	
Central controller			SCC-16, SCC-36	SCC-16, SCC-36	SCC-16, SCC-36	SCC-16, SCC-36	
Other			G2S, G2S-T, SAI-01, SBG-01				

The specification of products is subject to change based on further development of the units by the producer and can be changed without prior notice. Refer to rating label.

R32 (single component refrigerant HFC), GWP of refrigerant used: 675.

Contains fluorinated greenhouse gases covered by the Kyoto Protocol.

Explanatory notes on the very last page of the catalogue.

The device is being sold as a set (indoor + outdoor unit).

APPEARANCE AND DIMENSIONS OF INDOOR UNIT

SPECTRUM PLUS SERIES

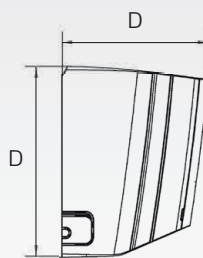
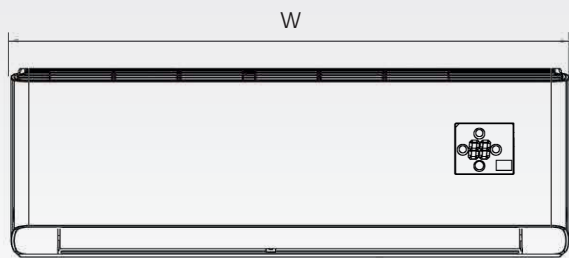

ASH-09BIS2/W

ASH-13BIS2/W

ASH-18BIS2/W

ASH-24BIS2/W

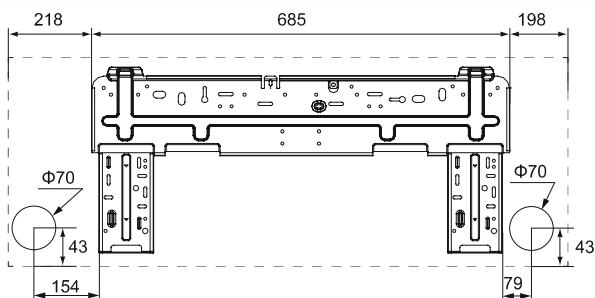
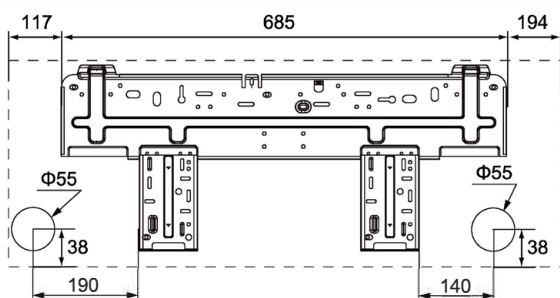

units: mm

APPEARANCE AND DIMENSIONS OF OUTDOOR UNIT

SPECTRUM PLUS SERIES

ASH-09BIS2/W

ASH-13BIS2/W

ASH-18BIS2/W

ASH-24BIS2/W

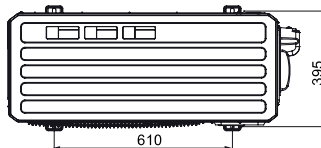
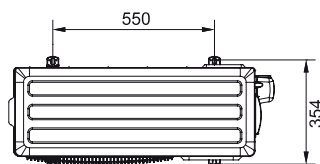
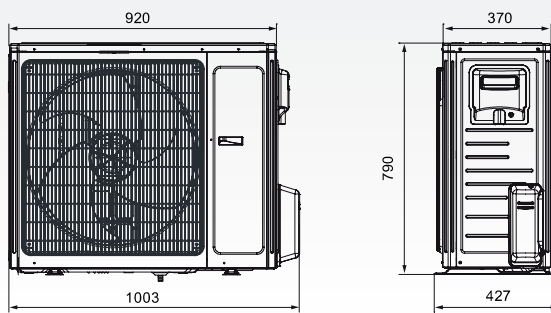
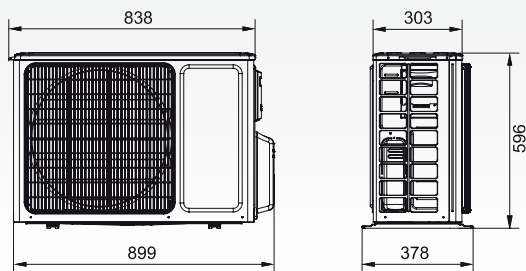

units: mm

ELECTRICAL WIRING DIAGRAM

SPECTRUM PLUS SERIES

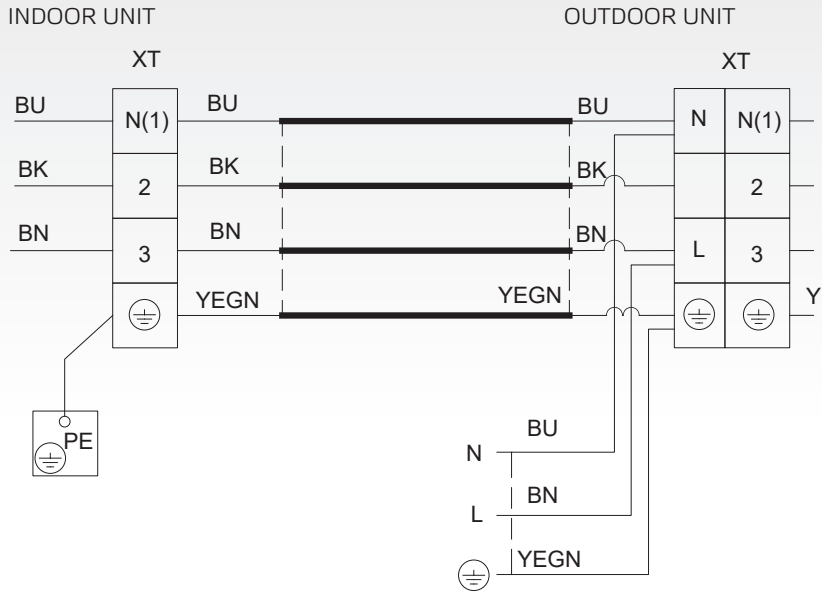

WALL MOUNTED SPLIT AIR CONDITIONERS

TERREL SERIES

MODEL			SIH+SOH-09BIT	SIH+SOH-13BIT	SIH+SOH-18BIT	SIH+SOH-24BIT
Capacity cooling/heating 1)	Nominal (min-max)	kW	2,7 (0,8-3,8) / 3,0 (0,9-4,2)	3,5 (1,0-3,8) / 3,8 (0,9-4,7)	5,2 (1,0-6,1) / 5,3 (1,1-6,0)	7,0 (2,0 - 8,5) / 7,4 (2,2-9,0)
Power supply		Hz / V	1~ / 50 / 220-240	1~ / 50 / 220-240	1~ / 50 / 220-240	1~ / 50 / 220-240
Power supply		-				
Power input cooling/heating 1)		W	695 / 700	962 / 953	1528 / 1410	1900 / 1897
Maximal power input 2)		W	1400	1550	2600	3750
Power current cooling/heating		A	3,1 / 3,2	4,3 / 4,6	6,8 / 6,2	8,7 / 8,8
Maximal power current 2)		A	6,2	6,9	11,5	17,5
Energy class cooling 3)		-	A+++	A+++	A++	A++
Pdesign cooling		kW	2,7	3,5	5,20	7
SEER		-	7,5	7,1	7	6,5
Annual power consumption cooling		kWh / annum	126	173	260	377
Energy class heating 3)	Aver./Warm./Cool.	-	A++ / A+++ / A	A+ / A+++ / A	A+ / A+++ / A	A+ / A+++ / A
Pdesign heating	Average climate	kW	2,7	3,2	4,20	6,40
SCOP	Average climate	-	4,2	4,1	4	4
Annual power consumption heating	Average climate	kWh / annum	900	1093	1470	2240
Airflow of ID	SH/H/M/L	m³ / h	610 / 570 / 540 / 470 / 440 / 420 / 390	700 / 650 / 600 / 540 / 480 / 420 / 360	800 / 720 / 650 / 610 / 570 / 520 / 470	1250 / 1100 / 1000 / 950 / 900 / 850 / 750
Airflow of OD	H	m³ / h	1950	1950	3200	3200
Sound pressure level of ID at 1m 4)	SH/H/M/L	dB(A)	38 / 36 / 34 / 31 / 29 / 27 / 25	42 / 38 / 35 / 32 / 29 / 27 / 25	45 / 43 / 41 / 38 / 36 / 34 / 31	48 / 45 / 42 / 39 / 37 / 36 / 33
Sound pressure level of OD at 1m 4)	H	dB(A)	50	52	57	57
Sound power of ID 4)	SH/H/M/L	dB(A)	56 / 48 / 46 / 43 / 41 / 39 / 37	57 / 50 / 47 / 44 / 41 / 39 / 37	59 / 57 / 55 / 52 / 49 / 48 / 45	58 / 55 / 52 / 49 / 47 / 46 / 43
Sound power of OD 4)	H	dB(A)	61	63	64	67
Dehumidifying volume		l / h	0,8	1,40	1,8	2,40
Refrigerant type/charge		Type / kg / t eq. CO ₂	R32 / 0,53 / 0,36	R32 / 0,57 / 0,38	R32 / 1 / 0,68	R32 / 1,70 / 1,18
Additional refrigerant		g / m	16	16	16	50
Pipe diameter - liquid side 5)		inch / mm	¼ / 6,0	¼ / 6,0	¼ / 6,0	¼ / 6,0
Pipe diameter - gas side 5)		inch / mm	¾ / 9,5	¾ / 9,5	½ / 12,0	¾ / 16,0
Max pipe length without additional refrigerant 6)		m	5	5	5	5
Allowed pipe length 7)	min./max.	m	3 / 15	3 / 15	3 / 25	3 / 25
Max. elevation/ Drop height		m	10	10	10	10
Dimension of ID	w x h x d	mm	889 x 294 x 212	889 x 294 x 212	1013 x 307 x 221	1122 x 329 x 247
Dimensions of OD	w x h x d	mm	732 x 555 x 330	732 x 555 x 330	965 x 700 x 396	965 x 700 x 396
Package dimension of ID	w x h x d	mm	940 x 365 x 284	940 x 365 x 284	1080 x 378 x 315	1177 x 406 x 332
Package dimensions of OD	w x h x d	mm	794 x 615 x 376	794 x 615 x 376	1029 x 750 x 458	1029 x 750 x 458
Weight of ID	net / gross	kg	11 / 13	11 / 13	13,5 / 16,5	17,5 / 21
Weight of OD	net / gross	kg	23,5 / 26	24,5 / 27	45 / 49,5	53,5 / 58
Set temperature range		°C	16 ~ 30	16 ~ 30	16 ~ 30	16 ~ 30
Operating temperature range cooling 8)		°C	-15 ~ 50	-15 ~ 50	-15 ~ 43	-15 ~ 43
Operating temperature range heating 8)		°C	-25 ~ 30	-25 ~ 30	-22 ~ 24	-22 ~ 24
ADDITIONAL TECHNICAL INFORMATION						
Screw holes distance of OD	w x d	mm	455 x 310	455 x 310	560 x 364	560 x 364
Communication cable		mm ²	4 x 0,75 (5m included)			
Recommended power cable		mm ²	3 x 1,5	3 x 1,5	3 x 1,5	3 x 4,0
Recommended air switch		A	13	13	13	20
EQUIPMENT						
Plasma generator	indoor		✓	✓	✓	✓
Wifi module			✓	✓	✓	✓
Drain pump			-	-	-	-
Max. lift (from bottom of ID unit)		mm	-	-	-	-
Dry contact (ON/OFF)			✓	✓	✓	✓
Alarm contact			-	-	-	-
Left-right guide louvres			✓	✓	-	-
Throttling method	outdoor		Capillary	EXV	EXV	EXV
Bottom chassis heater			✓	✓	✓	✓
Crankcase heater			Preheating	Preheating	Preheating	Preheating
Bottom plugs for OD			-	-	✓	✓
Drain pipe connector			✓	✓	✓	✓
STANDARD ACCESSORIES						
Standard health filter			SAF-OPWC4, SAF-OPWB4			
Remote controller (IR)			YAC1FB9 (Wifi)	YAC1FB9 (Wifi)	YAC1FB9 (Wifi)	YAC1FB9 (Wifi)
Wired controller			-	-	-	-
OPTIONAL ACCESSORIES						
Optional health filters			SAF-OPWA4, SAF-OPWK4, SAF-OPWM4, SAF-OPWP4, SAF-OPWS4			
Wired controller			SWC-02, XK19			
Central controller			SCC-16, SCC-36			
Other			G2S, G2S-T, SAI-01, SBG-01			

The specification of products is subject to change based on further development of the units by the producer and can be changed without prior notice. Refer to rating label.

R32 (single component refrigerant HFC), GWP of refrigerant used: 675.

Contains fluorinated greenhouse gases covered by the Kyoto Protocol.

Explanatory notes on the very last page of the catalogue.

The device is being sold as a set (indoor + outdoor unit).

APPEARANCE AND DIMENSIONS OF INDOOR UNIT

TERREL SERIES

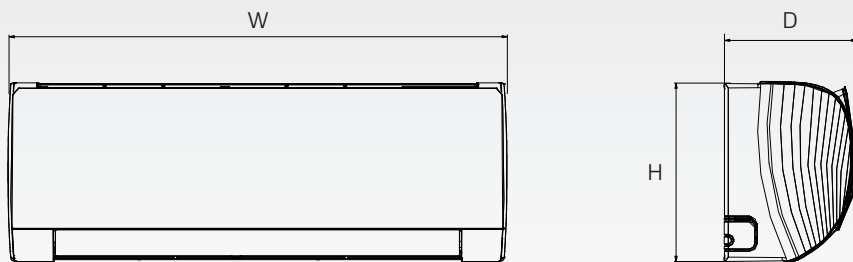

SIH-09BITx

SIH-13BITx

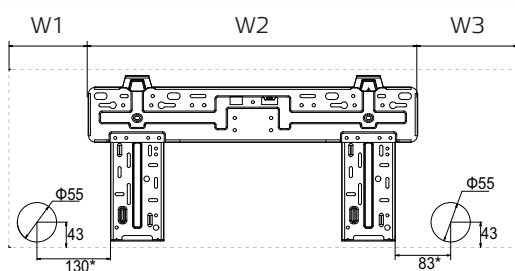

Model	W	H	D	W1	W2	W3
SIH-09/13BITx	889	294	212	146	542	201

units: mm

APPEARANCE AND DIMENSIONS OF OUTDOOR UNIT

TERREL SERIES

SOH-09BIT

SOH-13BIT

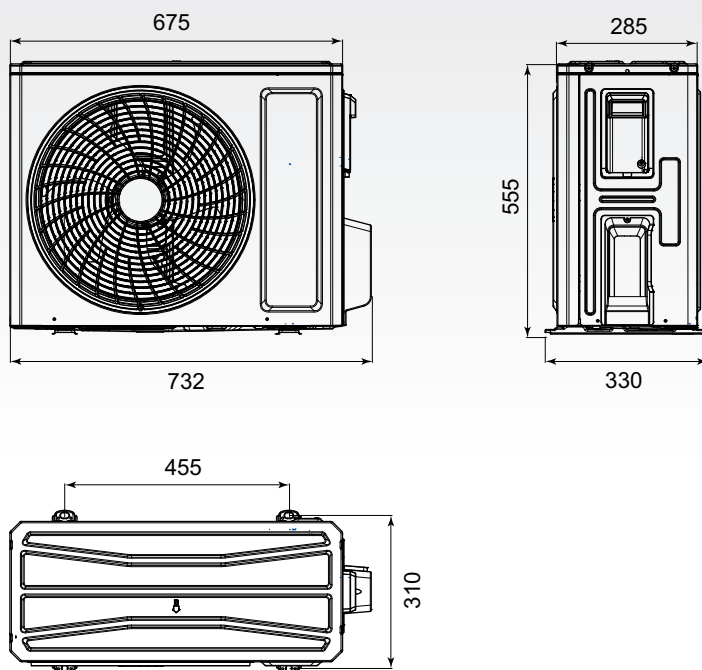

units: mm

APPEARANCE AND DIMENSIONS OF INDOOR UNIT

TERREL SERIES

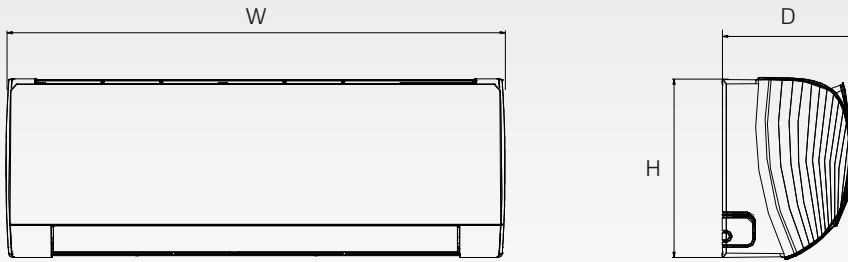

SIH-18BITx

SIH-24BITx

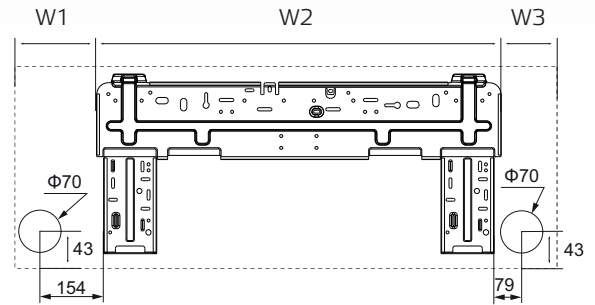
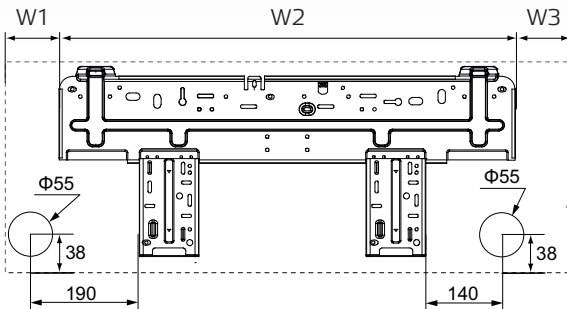

Models	W	H	D	W1	W2	W3
SIH-18BITx	1013	307	221	125.5	685	202.5
SIH-24BITx	1122	329	247	207	685	230

units: mm

APPEARANCE AND DIMENSIONS OF OUTDOOR UNIT

TERREL SERIES

SOH-18BIT

SOH-24BIT

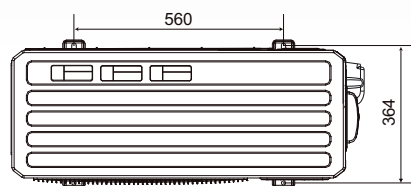
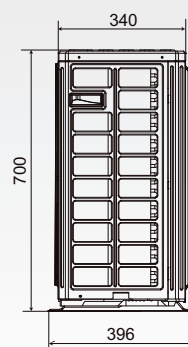
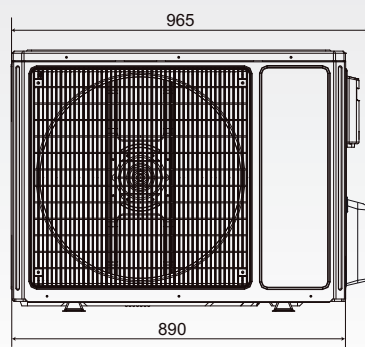

units: mm

WALL MOUNTED SPLIT AIR CONDITIONERS

KEYON SERIES

MODEL			SIH+SOH-09BIK	SIH+SOH-12BIK	SIH+SOH-18BIK	SIH+SOH-24BIK		
Capacity cooling/heating 1)	Nominal (min-max)	kW	2,7 (0,6-3,4) / 2,8 (0,6-3,7)	3,2 (0,9-3,7) / 3,4 (0,9-4,1)	4,6 (1,0-5,3) / 5,2 (1,0-5,65)	6,2 (1,8-6,4) / 6,5 (1,6-6,6)		
Power supply		Hz / V	1~ / 50 / 220-240	1~ / 50 / 220-240	1~ / 50 / 220-240	1~ / 50 / 220-240		
Power supply		-	outdoor	outdoor	outdoor	outdoor		
Power input cooling/heating 1)		W	735 / 695	991 / 916	1355 / 1340	1771 / 1646		
Maximal power input 2)		W	1500	1500	1900	2200		
Power current cooling/heating		A	3,5 / 3,3	4,4 / 4,0	5,9 / 5,8	7,9 / 7,3		
Maximal power current 2)		A	7,5	7,5	9,0	10,0		
Energy class cooling 3)		-	A++	A++	A++	A++		
Pdesign cooling		kW	2,7	3,2	4,6	6,2		
SEER		-	6,6	6,5	6,4	6,8		
Annual power consumption cooling		kWh / annum	143	172	251	319		
Energy class heating 3)	Aver./Warm./Cool.	-	A++ / A+++ / B	A++ / A+++ / -	A++ / A+++ / -	A++ / A+++ / -		
Pdesign heating	Average climate	kW	2,5	2,7	3,7	4,7		
SCOP	Average climate	-	4,2	4,1	4,0	4,0		
Annual power consumption heating	Average climate	kWh / annum	833	922	1295	1645		
Airflow of ID	SH/H/M/L	m³ / h	550 / 500 / 430 / 290	680 / 560 / 450 / 390	850 / 750 / 650 / 550	1100 / 950 / 750 / 650		
Airflow of OD	H	m³ / h	1950	1950	1950	2800		
Sound pressure level of ID at 1m 4)	SH/H/M/L	dB(A)	40 / 38 / 34 / 23	41 / 36 / 32 / 23	48 / 41 / 37 / 31	48 / 44 / 40 / 35		
Sound pressure level of OD at 1m 4)	H	dB(A)	51	52	53	58		
Sound power of ID 4)	SH/H/M/L	dB(A)	55 / 48 / 44 / 36	57 / 46 / 42 / 37	58 / 51 / 47 / 34	61 / 58 / 53 / 49		
Sound power of OD 4)	H	dB(A)	62	64	63	67		
Dehumidifying volume		l / h	1,4	1,4	1,8	1,8		
Refrigerant type/charge	Type / kg / t eq. CO ₂		R32 / 0,53 / 0,36	R32 / 0,57 / 0,38	R32 / 0,75 / 0,51	R32 / 1,30 / 0,88		
Additional refrigerant		g / m	16	16	16	16		
Pipe diameter - liquid side 5)		inch / mm	¼ / 6,0	¼ / 6,0	¼ / 6,0	¼ / 6,0		
Pipe diameter - gas side 5)		inch / mm	¾ / 9,5	¾ / 9,5	¾ / 9,5	¾ / 12,0		
Max pipe length without additional refrigerant 6)		m	5	5	5	5		
Allowed pipe length 7)	min./max.	m	3 / 15	3 / 15	3 / 25	3 / 25		
Max. elevation/ Drop height		m	10	10	10	10		
Dimension of ID	w x h x d	mm	770 x 251 x 190	849 x 289 x 215	972 x 300 x 225	1081 x 325 x 248		
Dimensions of OD	w x h x d	mm	732 x 550 x 330	732 x 550 x 330	732 x 550 x 330	873 x 555 x 376		
Package dimension of ID	w x h x d	mm	822 x 324 x 262	902 x 357 x 279	1022 x 374 x 299	1137 x 407 x 334		
Package dimensions of OD	w x h x d	mm	792 x 615 x 393	792 x 615 x 393	794 x 615 x 376	951 x 620 x 431		
Weight of ID	net / gross	kg	8,5 / 10,0	10,5 / 12,5	13,5 / 16,0	16,5 / 19,5		
Weight of OD	net / gross	kg	25 / 27,5	25 / 27,5	26,5 / 29	36,5 / 39,5		
Set temperature range		°C	16 ~ 30	16 ~ 30	16 ~ 30	16 ~ 30		
Operating temperature range cooling 8)		°C	-15 ~ 43	-15 ~ 43	-15 ~ 43	-15 ~ 43		
Operating temperature range heating 8)		°C	-15 ~ 24	-15 ~ 24	-15 ~ 24	-15 ~ 24		
ADDITIONAL TECHNICAL INFORMATION								
Screw holes distance of OD	w x d	mm	455 x 310			528 x 348,6		
Communication cable		mm ²	4 x 0,75 (5m included)					
Recommended power cable		mm ²	3x1,5	3x1,5	3x1,5	3x1,5		
Recommended air switch		A	13	13	13	13		
EQUIPMENT								
Plasma generator	indoor		✓	✓	✓	✓		
Wifi module			✓	✓	✓	✓		
Drain pump			-	-	-	-		
Max. lift (from bottom of ID unit)		mm	-	-	-	-		
Dry contact (ON/OFF)			-	✓	✓	✓		
Alarm contact			-	-	-	-		
Left-right guide louvres			-	-	-	-		
Throttling method	outdoor		Capillary	Capillary	Capillary	Capillary		
Bottom chassis heater			-	-	-	-		
Crankcase heater			Preheating	Preheating	Preheating	Preheating		
Bottom plugs for OD			-	-	-	-		
Drain pipe connector			-	-	✓	✓		
STANDARD ACCESSORIES								
Standard health filter			SAF-OPWC4, SAF-OPWA4					
Remote controller (IR)			YAA1FB6 (wifi)	YAA1FB6 (wifi)	YAA1FB6 (wifi)	YAA1FB6 (wifi)		
Wired controller			-	-	-	-		
OPTIONAL ACCESSORIES								
Optional health filters			SAF-OPWB4, SAF-OPWK4, SAF-OPWM4, SAF-OPWP4, SAF-OPWS4					
Wired controller			-	SWC-02, XK19				
Central controller			-	SCC-16, SCC-36				
Other			G2S, G2S-T, SAI-01	G2S, G2S-T, SAI-01, SBG-01	G2S, G2S-T, SAI-01, SBG-01	G2S, G2S-T, SAI-01, SBG-01		

The specification of products is subject to change based on further development of the units by the producer and can be changed without prior notice. Refer to rating label.

R32 (single component refrigerant HFC), GWP of refrigerant used: 675.

Contains fluorinated greenhouse gases covered by the Kyoto Protocol.

Explanatory notes on the very last page of the catalogue.

The device is being sold as a set (indoor + outdoor unit).

APPEARANCE AND DIMENSIONS OF INDOOR UNIT

KEYON PLUS SERIES

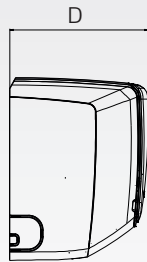
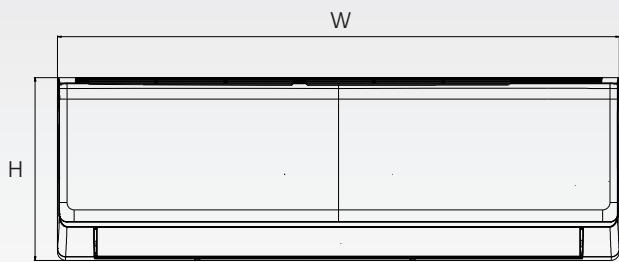

SIH-09BIK

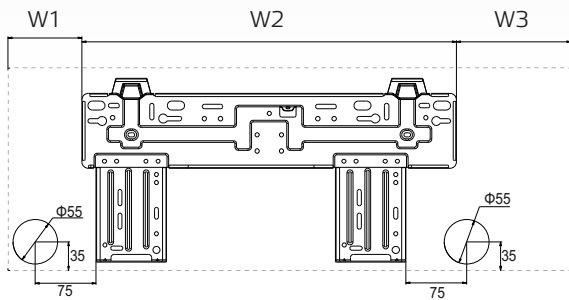

SIH-18BIK

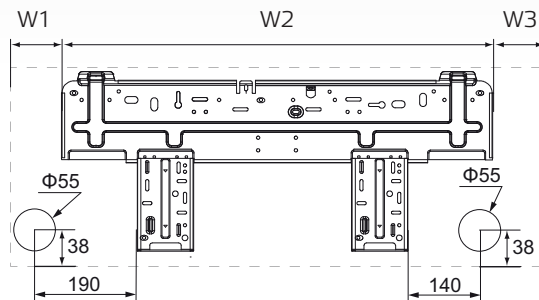

SIH-12BIK

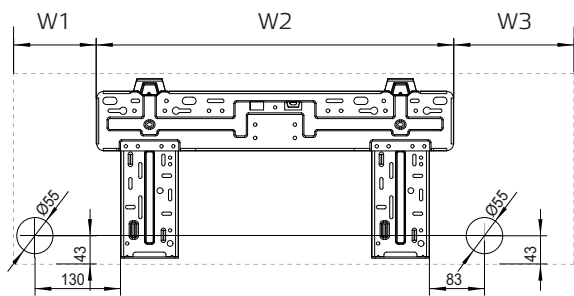

SIH-24BIK

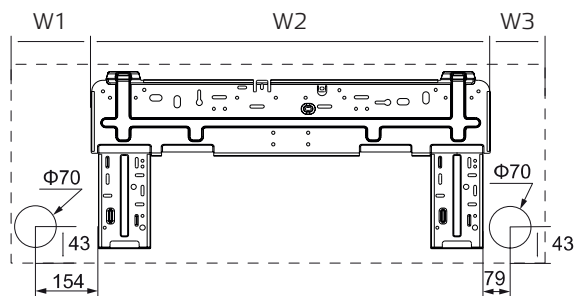

Model	W	H	D	W1	W2	W3
SIH-09BIK	770	251	190	129.5	462	178.5
SIH-12BIK	849	289	215	125	542	182
SIH-18BIK	972	300	225	105	685	182
SIH-24BIK	1081	325	248	207	685	189

units: mm

APPEARANCE AND DIMENSIONS OF OUTDOOR UNIT

KEYON PLUS SERIES

SOH-09BIK

SOH-12BIK

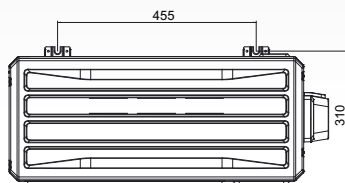
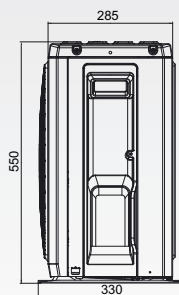
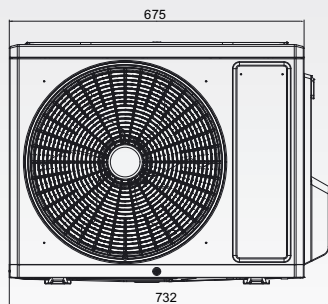

SOH-18BIK

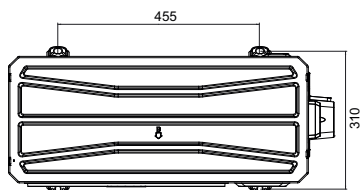
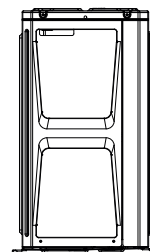
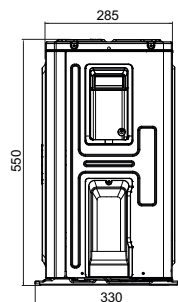
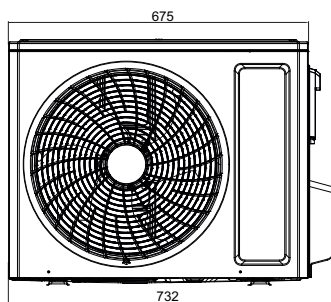

SOH-24BIK

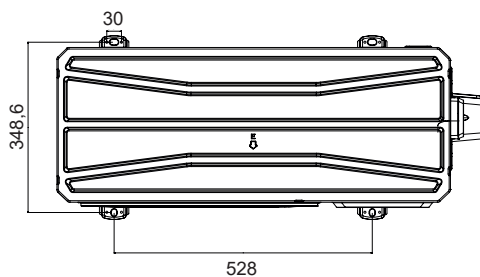
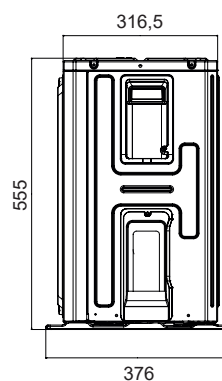
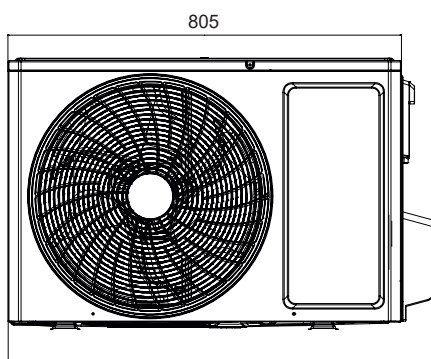

WALL MOUNTED SPLIT AIR CONDITIONERS

RAY SERIES

MODEL			SIH+SOH-09BIR	SIH+SOH-12BIR	SIH+SOH-18BIR	SIH+SOH-24BIR	
Capacity cooling/heating 1)	Nominal (min-max)	kW	2,7 (0,5-3,25) / 2,8 (0,5-3,5)	3,2 (0,9-3,6) / 3,4 (0,9-4,0)	4,6 (1,0-5,3) / 5,2 (1,0-5,6)	6,2 (1,8-6,9) / 6,5 (1,3-7,0)	
Power supply		Hz / V	1~ / 50 / 220-240	1~ / 50 / 220-240	1~ / 50 / 220-240	1~ / 50 / 220-240	
Power supply		-	outdoor	outdoor	outdoor	outdoor	
Power input cooling/heating 1)		W	735 / 695	991 / 916	1355 / 1340	1827 / 1912	
Maximal power input 2)		W	1500	1500	1900	2300	
Power current cooling/heating		A	3,5 / 3,3	4,4 / 4	5,9 / 5,8	7,6 / 7,6	
Maximal power current 2)		A	7,5	7,5	9,0	10,2	
Energy class cooling 3)		-	A++	A++	A++	A++	
Pdesign cooling		kW	2,7	3,2	4,6	6,2	
SEER		-	6,6	6,1	6,4	6,8	
Annual power consumption cooling		kWh / annum	143	184	264	350	
Energy class heating 3)	Aver./Warm./Cool.	-	A++ / A+++ / B	A++ / A+++ / B	A++ / A+++ / B	A++ / A+++ / B	
Pdesign heating	Average climate	kW	2,5	2,7	3,7	4,7	
SCOP	Average climate	-	4,2	4,0	4,0	4,0	
Annual power consumption heating	Average climate	kWh / annum	833	945	1260	1645	
Airflow of ID	SH/H/M/L	m³ / h	550 / 500 / 430 / 290	590 / 520 / 400 / 320	850 / 800 / 700 / 600	900 / 800 / 600 / 400	
Airflow of OD	H	m³ / h	1950	1950	1950	3200	
Sound pressure level of ID at 1m 4)	SH/H/M/L	dB(A)	40 / 36 / 34 / 23	41 / 37 / 33 / 26	44 / 42 / 38 / 31	48 / 45 / 37 / 30	
Sound pressure level of OD at 1m 4)	H	dB(A)	51	51	55	57	
Sound power of ID 4)	SH/H/M/L	dB(A)	55 / 48 / 44 / 36	56 / 49 / 45 / 38	54 / 52 / 48 / 41	58 / 55 / 47 / 40	
Sound power of OD 4)	H	dB(A)	62	64	63	65	
Dehumidifying volume		l / h	1,4	1,4	1,80	1,80	
Refrigerant type/charge	Type / kg / t eq. CO ₂		R32 / 0,5 / 0,34	R32 / 0,55 / 0,37	R32 / 0,75 / 0,51	R32 / 1,23 / 0,83	
Additional refrigerant		g / m	16	16	16	16	
Pipe diameter - liquid side 5)		inch / mm	¼ / 6,0	¼ / 6,0	¼ / 6,0	¼ / 6,0	
Pipe diameter - gas side 5)		inch / mm	¾ / 9,5	¾ / 9,5	¾ / 9,5	¾ / 12,0	
Max pipe length without additional refrigerant 6)		m	5	5	5	5	
Allowed pipe length 7)	min./max.	m	3 / 15	3 / 15	3 / 25	3 / 25	
Max. elevation/ Drop height		m	10	10	10	10	
Dimension of ID	w x h x d	mm	773 x 250 x 185	773 x 250 x 185	970 x 300 x 225	970 x 300 x 225	
Dimensions of OD	w x h x d	mm	732 x 550 x 330	732 x 550 x 330	732 x 555 x 330	873 x 555 x 376	
Package dimension of ID	w x h x d	mm	822 x 322 x 255	822 x 322 x 255	1020 x 369 x 295	1020 x 369 x 295	
Package dimensions of OD	w x h x d	mm	792 x 615 x 393	792 x 615 x 393	794 x 615 x 376	951 x 620 x 431	
Weight of ID	net / gross	kg	8,5 / 9,5	8 / 9,5	13,5 / 16,0	13 / 15,5	
Weight of OD	net / gross	kg	25 / 27,5	25 / 27,5	26,5 / 29,0	36,5 / 39,5	
Set temperature range		°C	16 ~ 30	16 ~ 30	16 ~ 30	16 ~ 30	
Operating temperature range cooling 8)		°C	-15 ~ 43	-15 ~ 43	-15 ~ 43	-15 ~ 43	
Operating temperature range heating 8)		°C	-15 ~ 24	-15 ~ 24	-15 ~ 24	-15 ~ 24	
ADDITIONAL TECHNICAL INFORMATION							
Screw holes distance of OD	w x d	mm	455 x 310	455 x 310	455 x 310	528 x 349	
Communication cable		mm ²	4 x 0,75 (5m included)				
Recommended power cable		mm ²	3 x 1,5	3 x 1,5	3 x 1,5	3 x 1,5	
Recommended air switch		A	13	13	13	13	
EQUIPMENT							
Plasma generator	indoor		✓	✓	✓	✓	
Wifi module			Optional (SWM-04)				
Drain pump			-	-	-	-	
Max. lift (from bottom of ID unit)		mm	-	-	-	-	
Dry contact (ON/OFF)			-	-	-	-	
Alarm contact			-	-	-	-	
Left-right guide louvres			-	-	-	-	
Throttling method	outdoor		Capillary	Capillary	Capillary	Capillary	
Bottom chassis heater			-	-	-	-	
Crankcase heater			Preheating	Preheating	Preheating	Preheating	
Bottom plugs for OD			-	-	-	-	
Drain pipe connector			-	-	-	-	
STANDARD ACCESSORIES							
Standard health filter			-	-	-	-	
Remote controller (IR)			YAW1F5 (wifi)	YAW1F5 (wifi)	YAW1F5 (wifi)	YAW1F5 (wifi)	
Wired controller			-	-	-	-	
OPTIONAL ACCESSORIES							
Optional health filters			SAF-OPWA4, SAF-OPWB4, SAF-OPWC4, SAF-OPWK4, SAF-OPWM4, SAF-OPWP4, SAF-OPWS4				
Wired controller			-	-	-	-	
Central controller			-	-	-	-	
Other			G2S, G2S-T, SAI-01, SWM-04	G2S, G2S-T, SAI-01, SWM-04	G2S, G2S-T, SAI-01, SWM-04	G2S, G2S-T, SAI-01, SWM-04	

The specification of products is subject to change based on further development of the units by the producer and can be changed without prior notice. Refer to rating label.

R32 (single component refrigerant HFC), GWP of refrigerant used: 675.

Contains fluorinated greenhouse gases covered by the Kyoto Protocol.

Explanatory notes on the very last page of the catalogue.

The device is being sold as a set (indoor + outdoor unit).

APPEARANCE AND DIMENSIONS OF INDOOR UNIT

RAY SERIES

SIH-09BIR, SIH-12BIR

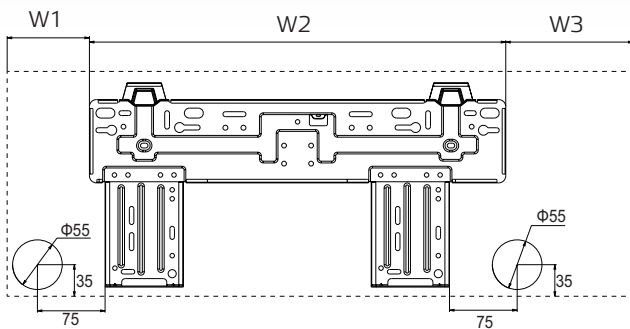
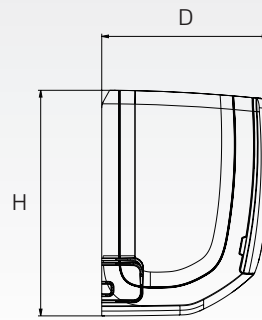
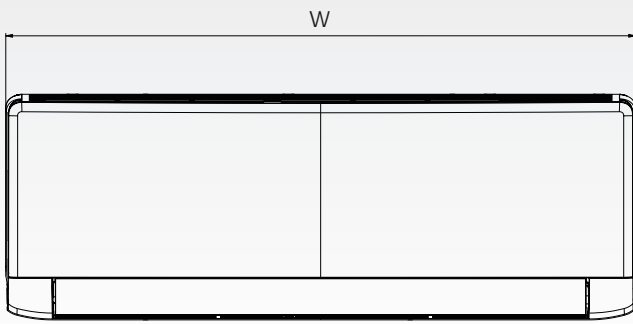

units: mm

Model	W	H	D	W1	W2	W3
SIH-09/12BIR	773	250	185	131	462	180

SIH-18BIR, SIH-24BIR

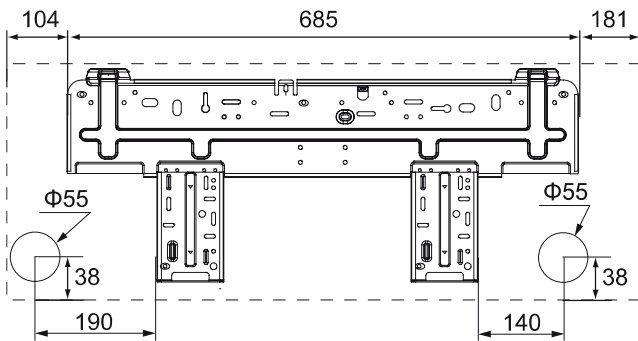
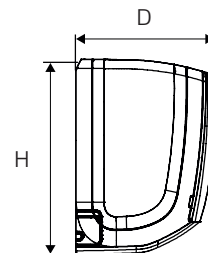
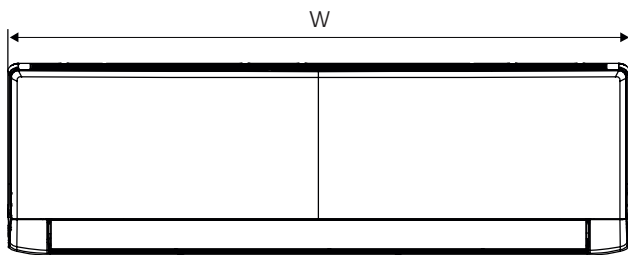

Model	W	H	D
SIH-18/24BIR	970	300	225

units: mm

APPEARANCE AND DIMENSIONS OF OUTDOOR UNIT

RAY SERIES

SOH-09BIR, SOH-12BIR

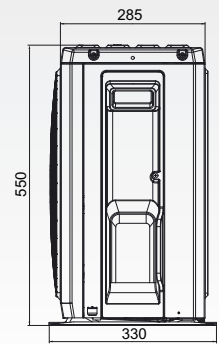
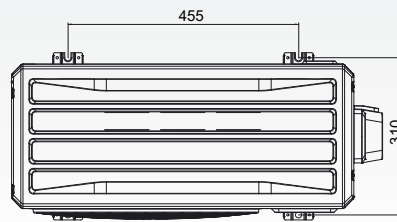
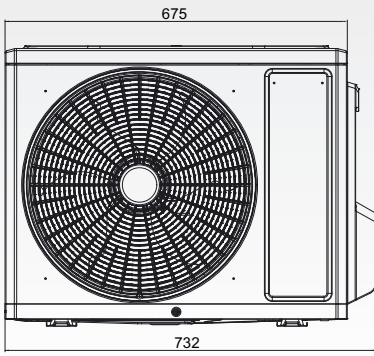

SOH-18BIR

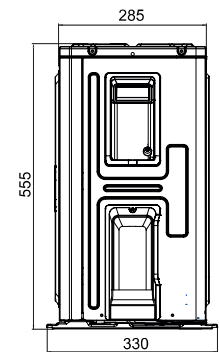
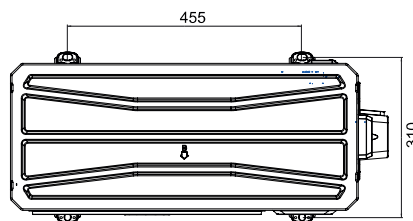
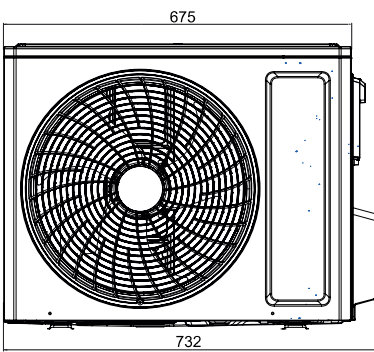

SOH-24BIR

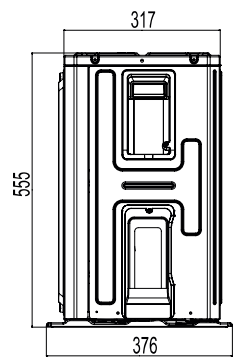
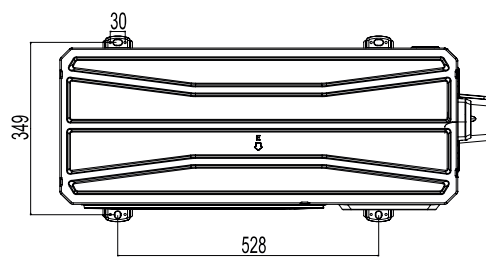
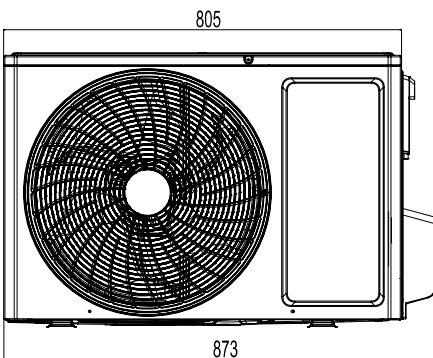

units: mm

ELECTRICAL WIRING DIAGRAM

RAY SERIES

INDOOR UNIT

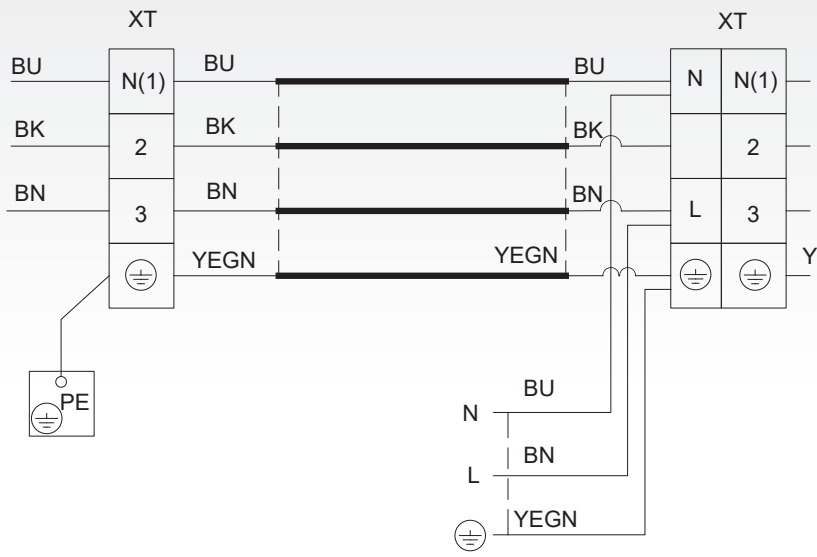

CONSOLE SPLIT AIR CONDITIONERS

CONSOLE SERIES

MODEL			ASP-09BI	ASP-12BI	ASP-18BI		
Capacity cooling/heating 1)	Nominal (min-max)	kW	2,7 (0,7-3,4) / 2,9 (0,6-3,5)	3,5 (0,8-4,4) / 3,8 (1,1-4,4)	5,2 (1,3-6,6) / 5,3 (1,1-6,8)		
Power supply		Hz / V	1~ / 50 / 220-240	1~ / 50 / 220-240	1~ / 50 / 220-240		
Power supply		-	outdoor	outdoor	outdoor		
Power input cooling/heating 1)		W	720 / 730	1000 / 960	1550 / 1500		
Maximal power input 2)		W	1350	1500	2500		
Power current cooling/heating		A	3,50 / 3,60	4,48 / 4,30	7,1 / 6,7		
Maximal power current 2)		A	6,00	6,72	10,9		
Energy class cooling 3)		-	A++	A++	A++		
Pdesign cooling		kW	2,7	3,5	5,2		
SEER		-	7,2	7,0	6,6		
Annual power consumption		kWh / annum	131	175	276		
Energy class heating 3)	Aver./Warm./Cool.	-	A+ / A+++ / -	A+ / A+++ / -	A+ / A+++ / -		
Pdesign heating	Average climate	kW	2,6	3,2	5,0		
SCOP	Average climate	-	4,0	4,1	4,1		
Annual power consumption	Average climate	kWh / annum	910	1093	1707		
Airflow of ID	SH/MH/H/ML/ML/SL	m³ / h	500 / 430 / 410 / 370 / 330 / 280 / 250	600 / 520 / 480 / 440 / 400 / 360 / 280	700 / 650 / 580 / 520 / 460 / 410 / 320		
Airflow of OD	H	m³ / h	1600	2200	3200		
Sound pressure level of ID at 1m 4)	SH/MH/H/ML/ML/SL	dB(A)	39 / 36 / 33 / 31 / 29 / 26 / 23	42 / 40 / 38 / 36 / 34 / 31 / 25	47 / 45 / 43 / 41 / 38 / 37 / 32		
Sound pressure level of OD at 1m 4)	H	dB(A)	49	52	57		
Sound power of ID 4)	SH/MH/H/ML/ML/SL	dB(A)	50 / 48 / 45 / 44 / 42 / 38 / 34	52 / 50 / 48 / 46 / 43 / 39 / 35	57 / 55 / 53 / 51 / 48 / 47 / 42		
Sound power of OD 4)	H	dB(A)	60	62	65		
Dehumidifying volume		l / h	0,8	1,2	1,8		
Refrigerant type/charge		Type / kg / t eq. CO ₂	R32 / 0,55 / 0,37	R32 / 0,75 / 0,51	R32 / 0,95 / 0,64		
Additional refrigerant		g / m	16	16	16		
Pipe diameter - liquid side 5)		inch / mm	¼ / 6,0	¼ / 6,0	¼ / 6,0		
Pipe diameter - gas side 5)		inch / mm	¾ / 9,5	¾ / 9,5	¾ / 12,0		
Max pipe length without additional refrigerant 6)		m	5	5	5		
Allowed pipe length 7)	Min/Max	m	3 / 20	3 / 20	3 / 25		
Max. elevation/ Drop height		m	10	10	10		
Dimension of ID	w x h x d	mm	700 x 600 x 215	700 x 600 x 215	700 x 600 x 215		
Dimensions of OD	w x h x d	mm	782 x 540 x 320	848 x 596 x 320	965 x 700 x 396		
Package dimension of ID	w x h x d	mm	785 x 682 x 280	785 x 682 x 280	785 x 682 x 280		
Package dimensions of OD	w x h x d	mm	823 x 595 x 358	881 x 645 x 363	1026 x 455 x 735		
Weight of ID	net / gross	kg	15,5 / 18,5	15,5 / 18,5	15,5 / 18,5		
Weight of OD	net / gross	kg	27,5 / 30,0	30,5 / 33,5	46,0 / 50,5		
Set temperature range		°C	16-30	16-30	16-30		
Operating temperature range cooling 8)		°C	-15-43	-15-43	-15-43		
Operating temperature range heating 8)		°C	-22-24	-22-24	-22-24		
ADDITIONAL TECHNICAL INFORMATION							
Screw holes distance of OD	w x d	mm	510 x 286	540 x 286	560 x 364		
Communication cable		mm ²	4 x 0,75 (5m included)				
Recommended power cable		mm ²	3 x 1,5	3 x 1,5	3 x 2,5		
Recommended air switch		A	10	13	16		
EQUIPMENT							
Plasma generator	indoor		✓	✓	✓		
Wifi module			✓	✓	✓		
Drain pump			-	-	-		
Max. lift (from bottom of ID unit)		mm	-	-	-		
Dry contact (ON/OFF)			-	-	-		
Alarm contact			-	-	-		
Fresh air inlet			-	-	-		
Throttling method	outdoor		EXV	EXV	EXV		
Bottom chassis heater			Heating belt	Heating belt	Heating belt		
Crankcase heater			Preheating	Preheating	Preheating		
Bottom plugs for OD			-	-	✓		
Drain pipe connector			✓	✓	✓		
STANDARD ACCESSORIES							
Standard health filter			SAF-OPWA4, SAF-OPWC4				
Remote controller (IR)			YAA1FB8	YAA1FB8	YAA1FB8		
Wired controller			-	-	-		
OPTIONAL ACCESSORIES							
Optional health filters			SAF-OPWB4, SAF-OPWK4, SAF-OPWM4, SAF-OPWP4, SAF-OPWS4				
Wired controller			SWC-02, XK19				
Central controller			SCC-16, SCC-36				
Other			G2S, G2S-T, SBG-01				

The specification of products is subject to change based on further development of the units by the producer and can be changed without prior notice. Refer to rating label.

R32 (single component refrigerant HFC), GWP of refrigerant used: 675.

Contains fluorinated greenhouse gases covered by the Kyoto Protocol.

Explanatory notes on the very last page of the catalogue.

The device is being sold as a set (indoor + outdoor unit).

APPEARANCE AND DIMENSIONS OF INDOOR UNIT

CONSOLE SERIES

ASP-09BI, ASP-12BI, ASP-18BI

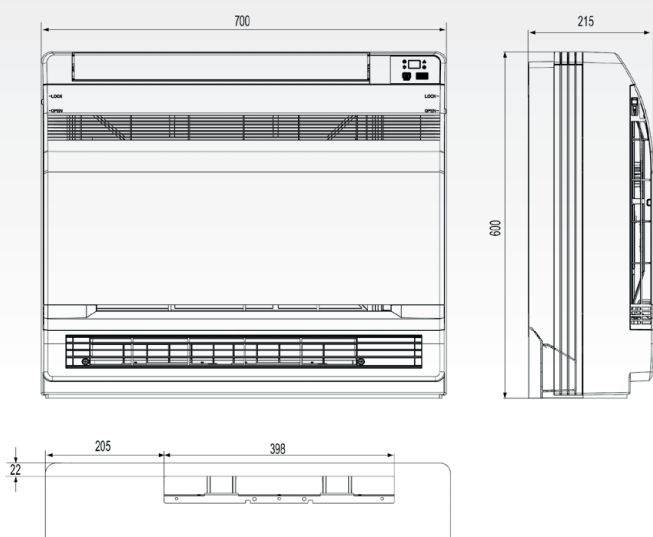

units: mm

DIMENSIONS OF OUTDOOR UNIT

CONSOLE SERIES

ASP-09BI

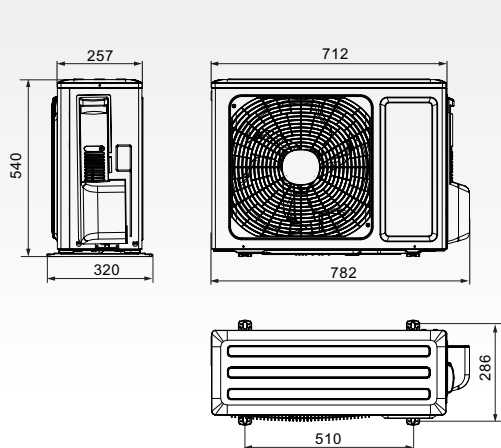

ASP-12BI

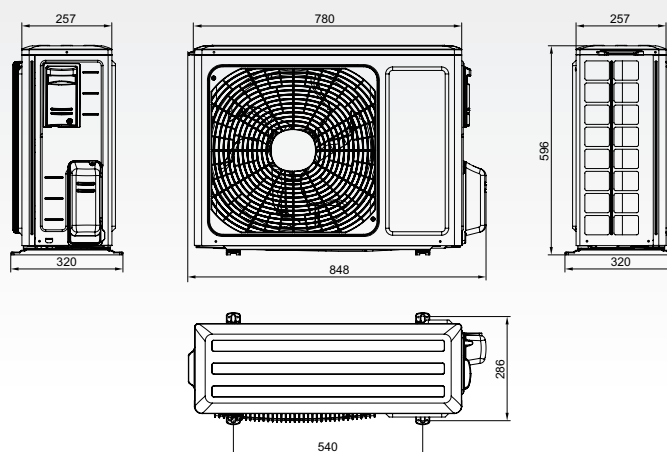

ASP-18BI

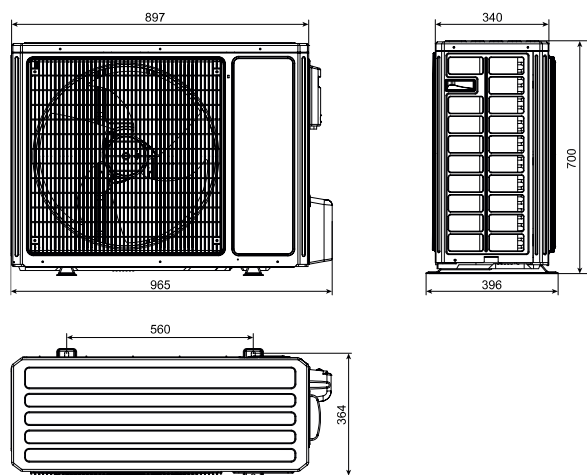

units: mm

ELECTRICAL WIRING DIAGRAM

CONSOLE SERIES

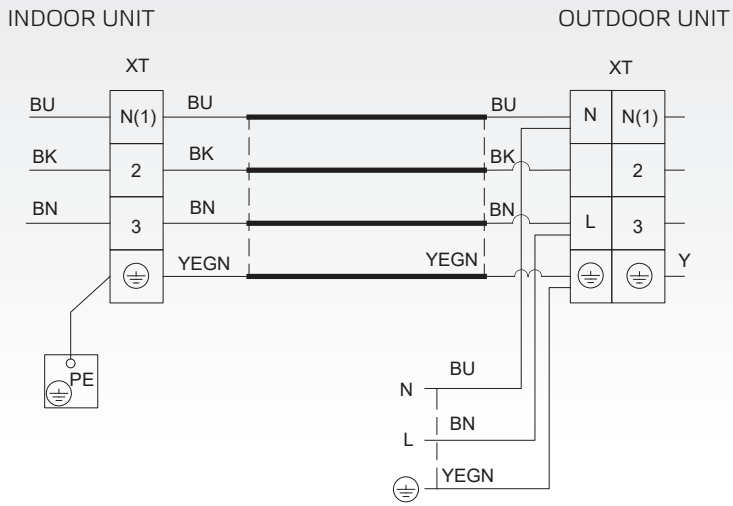

MULTI VARIABLE SERIES

MODEL			SIH-09BIT	SIH-13BIT	SIH-18BIT	SIH-24BIT
Capacity cooling/heating 1)	Nominal (min-max)	kW	2,7 (0,8-3,8) / 3,0 (0,9-4,2)	3,5 (1,0-3,8) / 3,8 (0,9-4,7)	5,2 (1,0-6,1) / 5,3 (1,1-6,0)	7,0 (2,0 - 8,5) / 7,4 (2,2-9,0)
Power supply		Hz / V	1~ / 50 / 220-240	1~ / 50 / 220-240	1~ / 50 / 220-240	1~ / 50 / 220-240
Airflow of ID	SH/MH/H/ML/ML/SL	m3 / h	610 / 570 / 540 / 470 / 440 / 420 / 390	700 / 650 / 600 / 540 / 480 / 420 / 360	800 / 720 / 650 / 610 / 570 / 520 / 470	1250 / 1100 / 1000 / 950 / 900 / 850 / 750
Sound pressure level of ID at 1m 4)	SH/MH/H/ML/ML/SL	dB(A)	38 / 36 / 34 / 31 / 29 / 27 / 25	42 / 38 / 35 / 32 / 29 / 27 / 25	45 / 43 / 41 / 38 / 36 / 34 / 31	48 / 45 / 42 / 39 / 37 / 36 / 33
Sound power of ID 4)	SH/MH/H/ML/ML/SL	dB(A)	56 / 48 / 46 / 43 / 41 / 39 / 37	57 / 50 / 47 / 44 / 41 / 39 / 37	59 / 57 / 55 / 52 / 49 / 48 / 45	58 / 55 / 52 / 49 / 47 / 46 / 43
Dehumidifying volume		l / h	0,69	1,40	1,8	2,40
Refrigerant type		Type	R32	R32	R32	R32
Pipe diameter - liquid side 5)		inch / mm	¼ / 6,0	¼ / 6,0	¼ / 6,0	¼ / 6,0
Pipe diameter - gas side 5)		inch / mm	¾ / 9,5	¾ / 9,5	¾ / 12,0	¾ / 16,0
Dimension of ID	w x h x d	mm	889 x 294 x 212	889 x 294 x 212	1013 x 307 x 221	1122 x 329 x 247
Package dimension of ID	w x h x d	mm	940 x 365 x 284	940 x 365 x 284	1080 x 378 x 315	1177 x 406 x 332
Weight of ID	net / gross	kg	11 / 13	11 / 13	13,5 / 16,5	17,5 / 21
Set temperature range		°C	16 ~ 30	16 ~ 30	16 ~ 30	16 ~ 30
ADDITIONAL TECHNICAL INFORMATION						
Communication cable		mm ²			4 x 0,75 (5m included)	
Recommended power cable		mm ²			Outdoor unit power supplied	
Recommended air switch		A			Outdoor unit power supplied	
EQUIPMENT						
Plasma generator	indoor		✓	✓	✓	✓
Wifi module			✓	✓	✓	✓
Drain pump			-	-	-	-
Max. lift (from bottom of ID unit)		mm	-	-	-	-
Dry contact (ON/OFF)			✓	✓	✓	✓
Alarm contact			-	-	-	-
Left-right guide louvres			✓	✓	-	-
STANDARD ACCESSORIES						
Standard health filter			SAF-OPWC4, SAF-OPWB4			
Remote controller (IR)			YAA1FB6 (wifi)	YAA1FB6 (wifi)	YAA1FB6 (wifi)	YAA1FB6 (wifi)
Wired controller			-	-	-	-
OPTIONAL ACCESSORIES						
Optional health filters			SAF-OPWA4, SAF-OPWK4, SAF-OPWM4, SAF-OPWP4, SAF-OPWS4			
Wired controller			SWC-02, XK19			
Central controller			SCC-16, SCC-36			
Other			G2S, G2S-T, SAI-01, SBG-01	G2S, G2S-T, SAI-01, SBG-01	G2S, G2S-T, SAI-01, SBG-01	G2S, G2S-T, SAI-01, SBG-01

The specification of products is subject to change based on further development of the units by the producer and can be changed without prior notice. Refer to rating label.

R32 (single component refrigerant HFC), GWP of refrigerant used: 675.

Contains fluorinated greenhouse gases covered by the Kyoto Protocol.

Explanatory notes on the very last page of the catalogue.

These indoor units may be combined with other indoor units from MULTI VARIABLE series, it is essential to follow combinations recommended in the combination table.

MULTI VARIABLE SERIES

MODEL			SIH-07BIK	SIH-09BIK	SIH-12BIK	SIH-18BIK	SIH-24BIK
Capacity cooling/heating 1)	Nominal (min-max)	kW	2,2 (0,3-2,8) / 2,4 (0,6-2,9)	2,7 (0,6-3,4) / 2,8 (0,6-3,7)	3,2 (0,9-3,7) / 3,4 (0,9-4,1)	4,6 (1,0-5,3) / 5,2 (1,0-5,65)	6,2 (1,8-6,4) / 6,5 (1,6-6,6)
Power supply		Hz / V	1~ / 50 / 220-240	1~ / 50 / 220-240	1~ / 50 / 220-240	1~ / 50 / 220-240	1~ / 50 / 220-240
Airflow of ID	SH/MH/H/ML/ML/SL	m ³ / h	520/470/420/250	550 / 500 / 430 / 290	680 / 560 / 450 / 390	850 / 750 / 650 / 550	1100 / 950 / 750 / 650
Sound pressure level of ID at 1m 4)	SH/MH/H/ML/ML/SL	dB(A)	39/37/33/22	40 / 38 / 34 / 23	41 / 36 / 32 / 23	48 / 41 / 37 / 31	48 / 44 / 40 / 35
Sound power of ID 4)	SH/MH/H/ML/ML/SL	dB(A)	55/49/45/34	55 / 48 / 44 / 36	57 / 46 / 42 / 37	58 / 51 / 47 / 34	61 / 58 / 53 / 49
Dehumidifying volume		l / h	0,6	1,4	1,4	1,8	1,8
Refrigerant type		Type	R32	R32	R32	R32	R32
Pipe diameter - liquid side 5)		inch / mm	¼ / 6,0	¼ / 6,0	¼ / 6,0	¼ / 6,0	¼ / 6,0
Pipe diameter - gas side 5)		inch / mm	¾ / 9,5	¾ / 9,5	¾ / 9,5	¾ / 9,5	½ / 12,0
Dimension of ID	w x h x d	mm	696x251x190	770 x 251 x 190	849 x 289 x 215	972 x 300 x 225	1081 x 325 x 248
Package dimension of ID	w x h x d	mm	747x324x262	822 x 324 x 262	902 x 357 x 279	1022 x 374 x 299	1137 x 407 x 334
Weight of ID	net / gross	kg	7,5 / 9,0	8,5 / 10,0	10,5 / 12,5	13,5 / 16,0	16,5 / 19,5
Set temperature range		°C	16 ~ 30	16 ~ 30	16 ~ 30	16 ~ 30	16 ~ 30

ADDITIONAL TECHNICAL INFORMATION

Communication cable		mm ²	4 x 0,75 (5m included)				
Recommended power cable		mm ²	Outdoor unit power supplied				
Recommended air switch		A	Outdoor unit power supplied				

EQUIPMENT

Plasma generator	indoor		✓	✓	✓	✓	✓
Wifi module			✓	✓	✓	✓	✓
Drain pump			-	-	-	-	-
Max. lift (from bottom of ID unit)		mm	-	-	-	-	-
Dry contact (ON/OFF)			-	-	✓	✓	✓
Alarm contact			-	-	-	-	-
Left-right guide louvres			-	-	-	-	-

STANDARD ACCESSORIES

Standard health filter			SAF-OPWC4, SAF-OPWA4				
Remote controller (IR)			YAA1FB6 (wifi)	YAA1FB6 (wifi)	YAA1FB6 (wifi)	YAA1FB6 (wifi)	YAA1FB6 (wifi)
Wired controller			-	-	-	-	-

OPTIONAL ACCESSORIES

Optional health filters			SAF-OPWB4, SAF-OPWK4, SAF-OPWM4, SAF-OPWP4, SAF-OPWS4				
Wired controller			-	-	SWC-02, XK19		
Central controller			-	-	SCC-16, SCC-36		
Other			G2S, G2S-T, SAI-01		G2S, G2S-T, SAI-01, SBG-01	G2S, G2S-T, SAI-01, SBG-01	G2S, G2S-T, SAI-01, SBG-01

The specification of products is subject to change based on further development of the units by the producer and can be changed without prior notice. Refer to rating label.

R32 (single component refrigerant HFC), GWP of refrigerant used: 675.

Contains fluorinated greenhouse gases covered by the Kyoto Protocol.

Explanatory notes on the very last page of the catalogue.

These indoor units may be combined with other indoor units from MULTI VARIABLE series, it is essential to follow combinations recommended in the combination table.

APPEARANCE AND DIMENSIONS OF INDOOR UNIT

SIH-07BIK

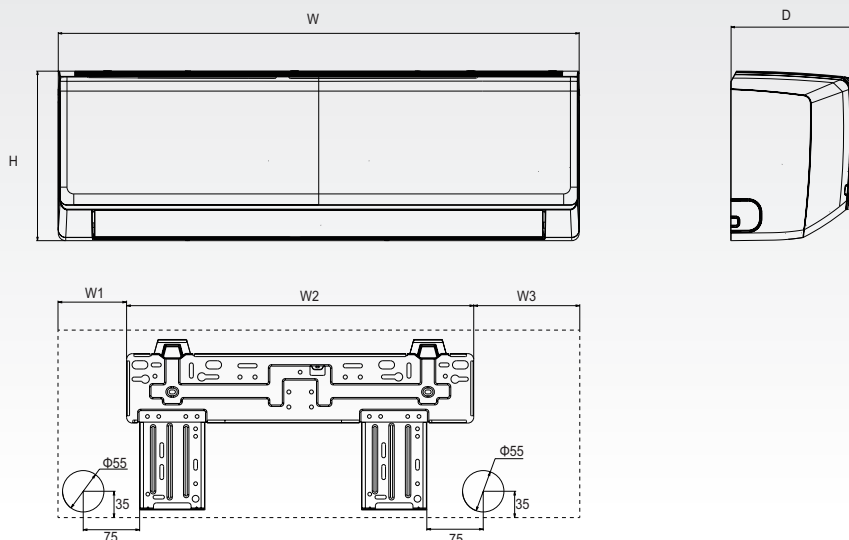

Models	W	H	D	W1	W2	W3
SIH-07BIK	696	251	190	92	462	142

WALL MOUNTED AIR CONDITIONERS RAY

MULTI VARIABLE SERIES

MODEL			SIH-09BIR	SIH-12BIR	SIH-18BIR	SIH-24BIR
Capacity cooling/heating 1)	Nominal (min-max)	kW	2,7 (0,5-3,25) / 2,8 (0,5-3,5)	3,2 (0,9-3,6) / 3,4 (0,9-4,0)	4,6 (1,0-5,3) / 5,3 (1,0-5,6)	6,2 (1,8-6,9) / 6,5 (1,3-7,0)
Power supply		Hz / V	1~ / 50 / 220-240	1~ / 50 / 220-240	1~ / 50 / 220-240	1~ / 50 / 220-240
Airflow of ID	SH/MH/H/ML/ML/SL	m ³ / h	550 / 500 / 430 / 290	590 / 520 / 400 / 320	850 / 800 / 700 / 600	900 / 800 / 600 / 400
Sound pressure level of ID at 1m 4)	SH/MH/H/ML/ML/SL	dB(A)	40 / 36 / 34 / 23	41 / 37 / 33 / 26	44 / 42 / 38 / 31	48 / 45 / 37 / 30
Sound power of ID 4)	SH/MH/H/ML/ML/SL	dB(A)	55 / 48 / 44 / 36	56 / 49 / 45 / 38	54 / 52 / 48 / 41	58 / 55 / 47 / 40
Dehumidifying volume		l / h	1,4	1,4	1,80	1,80
Refrigerant type		Type	R32	R32	R32	R32
Pipe diameter - liquid side 5)		inch / mm	¼ / 6,0	¼ / 6,0	¼ / 6,0	¼ / 6,0
Pipe diameter - gas side 5)		inch / mm	¾ / 9,5	¾ / 9,5	¾ / 9,5	¾ / 12,0
Dimension of ID	w x h x d	mm	773 x 250 x 185	773 x 250 x 185	970 x 300 x 225	970 x 300 x 225
Package dimension of ID	w x h x d	mm	822 x 322 x 255	822 x 322 x 255	1020 x 369 x 295	1020 x 369 x 295
Weight of ID	net / gross	kg	8,5 / 9,5	8 / 9,5	13,5 / 16,0	13,5 / 16,5
Set temperature range		°C	16 ~ 30	16 ~ 30	16 ~ 30	16 ~ 30
ADDITIONAL TECHNICAL INFORMATION						
Communication cable		mm ²	4 x 0,75 (5m included)			
Recommended power cable		mm ²	Outdoor unit power supplied			
Recommended air switch		A	Outdoor unit power supplied			
EQUIPMENT						
Plasma generator	indoor		✓	✓	✓	✓
Wifi module			Optional (SWM-04)			
Drain pump			-	-	-	-
Max. lift (from bottom of ID unit)		mm	-	-	-	-
Dry contact (ON/OFF)			-	-	-	-
Alarm contact			-	-	-	-
Left-right guide louvres			-	-	-	-
STANDARD ACCESSORIES						
Standard health filter			-	-	-	-
Remote controller (IR)			YAW1F5 (wifi)	YAW1F5 (wifi)	YAW1F5 (wifi)	YAW1F5 (wifi)
Wired controller			-	-	-	-
OPTIONAL ACCESSORIES						
Optional health filters			SAF-OPWA4, SAF-OPWB4, SAF-OPWC4, SAF-OPWK4, SAF-OPWM4, SAF-OPWP4, SAF-OPWS4			
Wired controller			-	-	-	-
Central controller			-	-	-	-
Other			G2S, G2S-T, SAI-01, SWM-04	G2S, G2S-T, SAI-01, SWM-04	G2S, G2S-T, SAI-01, SWM-04	G2S, G2S-T, SAI-01, SWM-04

The specification of products is subject to change based on further development of the units by the producer and can be changed without prior notice. Refer to rating label.

R32 (single component refrigerant HFC), GWP of refrigerant used: 675.

Contains fluorinated greenhouse gases covered by the Kyoto Protocol.

Explanatory notes on the very last page of the catalogue.

These indoor units may be combined with other indoor units from MULTI VARIABLE series, it is essential to follow combinations recommended in the combination table.

CONSOLE INDOOR UNITS

MULTI VARIABLE SERIES

MODEL			MV-P09BI	MV-P12BI	MV-P18BI		
Capacity cooling/heating 1)	Nominal	kW	2,7 / 2,8	3,5 / 3,75	5,2 / 5,33		
Power supply		Hz / V	1~ / 50 / 220-240	1~ / 50 / 220-240	1~ / 50 / 220-240		
Airflow of ID	SH/MH/H/ML/ML/SL	m ³ / h	500 / 430 / 410 / 370 / 330 / 280 / 250	600 / 520 / 480 / 440 / 400 / 360 / 280	700 / 650 / 580 / 520 / 460 / 410 / 320		
Sound pressure level of ID at 1m 4)	SH/MH/H/ML/ML/SL	dB(A)	40 / 36 / 34 / 32 / 30 / 26 / 23	42 / 40 / 38 / 36 / 34 / 31 / 25	47 / 45 / 42 / 40 / 37 / 35 / 31		
Sound power of ID 4)	SH/MH/H/ML/ML/SL	dB(A)	52 / 48 / 46 / 44 / 42 / 38 / 34	52 / 50 / 48 / 46 / 44 / 41 / 35	57 / 55 / 52 / 50 / 47 / 45 / 41		
External static pressure	nom/min-max	Pa	-	-	-		
Dehumidifying volume		l / h	0,8	1,2	3,8		
Refrigerant type		Type	R32	R32	R32		
Pipe diameter - liquid side 5)		inch / mm	¼ / 6,0	¼ / 6,0	¼ / 6,0		
Pipe diameter - gas side 5)		inch / mm	¾ / 9,5	¾ / 9,5	¾ / 12,0		
Dimension of ID	w x h x d	mm	700 x 600 x 215	700 x 600 x 215	700 x 600 x 215		
Dimension of panel	w x h x d	mm	-	-	-		
Package dimension of ID	w x h x d	mm	788 x 697 x 283	788 x 697 x 283	788 x 697 x 283		
Package dimension of panel	w x h x d	mm	-	-	-		
Weight of ID	net / gross	kg	15,5 / 18,5	15,5 / 18,5	15,5 / 18,5		
Weight of panel	net / gross	kg	-	-	-		
Set temperature range		°C	16 ~ 30	16 ~ 30	16 ~ 30		
ADDITIONAL TECHNICAL INFORMATION							
Screw holes distance	w x d	mm	See service manual				
Communication cable		mm ²	4 x 0,75				
Recommended power cable 11)		mm ²	Outdoor unit power supplied				
Recommended air switch		A	Outdoor unit power supplied				
EQUIPMENT							
Plasma generator			✓	✓	✓		
Wifi module			✓	✓	✓		
Drain pump			-	-	-		
Max. lift (from bottom of ID unit)		mm	-	-	-		
Dry contact (ON/OFF)			-	-	-		
Alarm contact			-	-	-		
Fresh air inlet			-	-	-		
STANDARD ACCESSORIES							
Standard health filter			SAF-OPWC1, SAF-OPWA1				
Remote controller (IR)			YAA1FB8	YAA1FB8	YAA1FB8		
Wired controller			-	-	-		
OPTIONAL ACCESSORIES							
Optional health filters			SAF-OPWB4, SAF-OPWK4, SAF-OPWM4, SAF-OPWP4, SAF-OPWS4				
Wired controller			SWC-02, XK19				
Central controller			SCC-16, SCC-36				
Other			G2S, G2S-T, SBG-01				

The specification of products is subject to change based on further development of the units by the producer and can be changed without prior notice. Refer to rating label.

R32 (single component refrigerant HFC), GWP of refrigerant used: 675.

Contains fluorinated greenhouse gases covered by the Kyoto Protocol.

Explanatory notes on the very last page of the catalogue.

These indoor units may be combined with other indoor units from MULTI VARIABLE series, it is essential to follow combinations recommended in the combination table.

APPEARANCE AND DIMENSIONS OF INDOOR UNIT

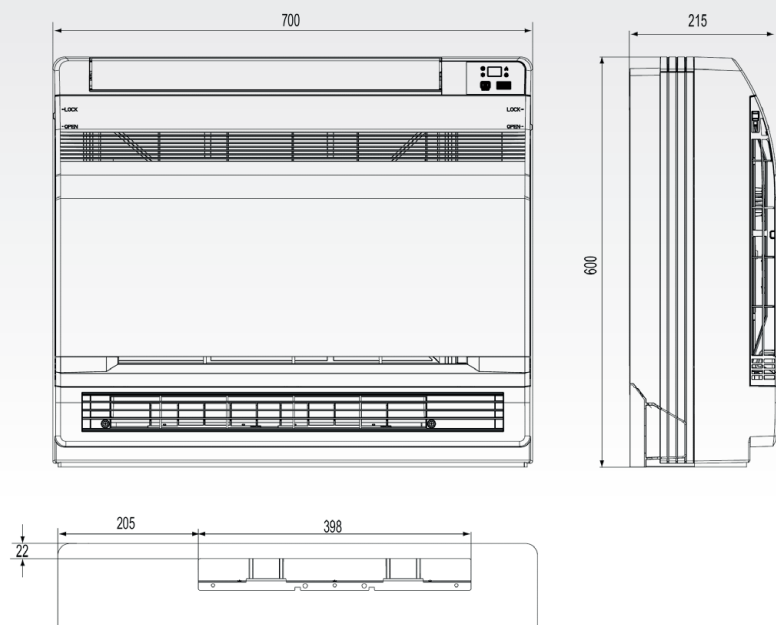

units: mm

FLOOR CEILING INDOOR UNITS

MULTI VARIABLE SERIES

MODEL			MV-F09BI	MV-F12BI	MV-F18BI	MV-F24BI		
Capacity cooling/heating 1)	Nominal	kW	2,6 / 2,7	3,5 / 4	4,5 / 5	7,1 / 8		
Power supply		Hz / V	1~ / 50 / 220-240	1~ / 50 / 220-240	1~ / 50 / 220-240	1~ / 50 / 220-240		
Airflow of ID	SH/H/M/L	m ³ / h	700 / 610 / 540 / 420	700 / 610 / 540 / 420	680 / 590 / 520 / 410	950 / 870 / 800 / 720		
Sound pressure level of ID at 1m 4)	SH/H/M/L	dB(A)	38 / 35 / 30 / 26	38 / 35 / 30 / 26	38 / 35 / 30 / 26	38 / 35 / 30 / 26		
Sound power of ID 4)	SH/H/M/L	dB(A)	52 / 49 / 44 / 40	52 / 49 / 44 / 40	52 / 49 / 44 / 40	52 / 49 / 44 / 41		
External static pressure	nom/min-max	Pa	-	-	-	-		
Dehumidifying volume		l / h	0,8	1,4	1,8	2,5		
Refrigerant type		Type	R32	R32	R32	R32		
Pipe diameter - liquid side 5)		inch / mm	¼ / 6,0	¼ / 6,0	¼ / 6,0	¼ / 9,5		
Pipe diameter - gas side 5)		inch / mm	¾ / 9,5	¾ / 12,0	¾ / 12,0	¾ / 16,0		
Dimension of ID	w x h x d	mm	870 x 665 x 235	870 x 665 x 235	870 x 665 x 235	1200 x 665 x 235		
Dimension of panel	w x h x d	mm	-	-	-	-		
Package dimension of ID	w x h x d	mm	1033 x 770 x 300	1033 x 770 x 300	1033 x 770 x 300	1363 x 770 x 300		
Package dimension of panel	w x h x d	mm	-	-	-	-		
Weight of ID	net / gross	kg	25 / 30	25 / 30	25,5 / 30,5	33 / 40		
Weight of panel	net / gross	kg	-	-	-	-		
Set temperature range		°C	16 ~ 30	16 ~ 30	16 ~ 30	16 ~ 30		
ADDITIONAL TECHNICAL INFORMATION								
Screw holes distance	w x d	mm	See service manual					
Communication cable		mm ²	4 x 1,0	4 x 1,0	4 x 1,0	4 x 1,0		
Recommended power cable 11)		mm ²	Outdoor unit power supplied					
Recommended air switch		A	Outdoor unit power supplied					
EQUIPMENT								
Plasma generator			-	-	-	-		
Wifi module			-	-	-	-		
Drain pump			-	-	-	-		
Max. lift (from bottom of ID unit)		mm	-	-	-	-		
Dry contact (ON/OFF)			✓	✓	✓	✓		
Alarm contact			-	-	-	-		
Fresh air inlet			-	-	-	-		
STANDARD ACCESSORIES								
Standard health filter			-	-	-	-		
Remote controller (IR)			YT1F	YT1F	YT1F	YT1F		
Wired controller			✓	✓	✓	✓		
OPTIONAL ACCESSORIES								
Optional health filters			-					
Wired controller			SWC-02					
Central controller			SCC-16, SCC-36					
Other			G2S, G2S-T, SBG-01					

The specification of products is subject to change based on further development of the units by the producer and can be changed without prior notice. Refer to rating label.

R32 (single component refrigerant HFC), GWP of refrigerant used: 675.

Contains fluorinated greenhouse gases covered by the Kyoto Protocol.

Explanatory notes on the very last page of the catalogue.

These indoor units may be combined with other indoor units from MULTI VARIABLE series, it is essential to follow combinations recommended in the combination table.

APPEARANCE AND DIMENSIONS OF INDOOR UNIT

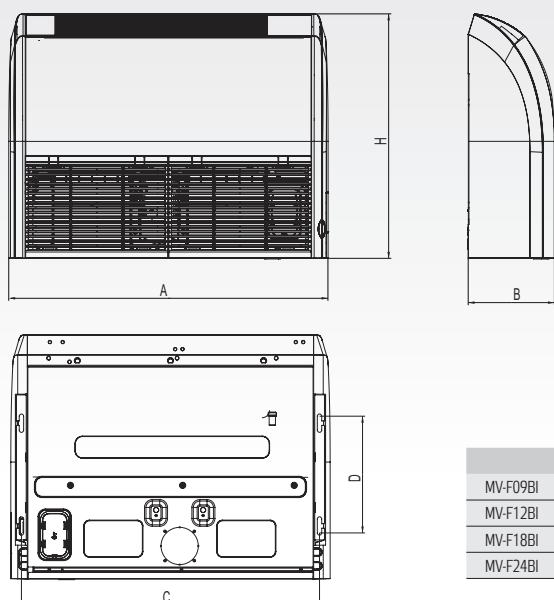

	A	B	C	D	H
MV-F09BI					
MV-F12BI	870	235	812	318	665
MV-F18BI					
MV-F24BI	1200	235	1142	318	665

units: mm

CASSETTE INDOOR UNITS

MULTI VARIABLE SERIES

MODEL			MV-C12BI2	MV-C18BI2	MV-C24BI2		
Capacity cooling/heating 1)	Nominal	kW	3,5 / 4,0	5,0 / 5,5	7,0 / 8,0		
Power supply		Hz / V	1~ / 50 / 220-240	1~ / 50 / 220-240	1~ / 50 / 220-240		
Airflow of ID	SH/H/M/L	m ³ / h	560 / 490 / 420 / 350	650 / 490 / 420 / 350	1100 / 950 / 870 / 800		
Sound pressure level of ID at 1,4m 4)	SH/H/M/L	dB(A)	41 / 36 / 32 / 28	43 / 36 / 32 / 28	46 / 44 / 42 / 37		
Sound power of ID 4)	SH/H/M/L	dB(A)	57 / 52 / 48 / 44	59 / 52 / 48 / 44	61 / 59 / 57 / 55		
External static pressure	nom/min-max	Pa	-	-	-		
Dehumidifying volume		l / h	1,4	1,8	2,5		
Refrigerant type		Type	R32	R32	R32		
Pipe diameter - liquid side 5)		inch / mm	¼ / 6,0	¼ / 6,0	¼ / 6,0		
Pipe diameter - gas side 5)		inch / mm	¾ / 9,5	¾ / 12,0	¾ / 16,0		
Dimension of ID	w x h x d	mm	570 x 265 x 570	570 x 265 x 570	840 x 240 x 840		
Dimension of panel	w x h x d	mm	620 x 47,5 x 620	620 x 47,5 x 620	950 x 52 x 950		
Package dimension of ID	w x h x d	mm	698 x 295 x 653	698 x 295 x 653	963 x 325 x 963		
Package dimension of panel	w x h x d	mm	701 x 125 x 701	701 x 125 x 701	1033 x 112 x 1038		
Weight of ID	net / gross	kg	17 / 22	17 / 22	29 / 36		
Weight of panel	net / gross	kg	3,0 / 4,0	3,0 / 4,0	6,0 / 9,5		
Set temperature range		°C	16 ~ 30	16 ~ 30	16 ~ 30		
ADDITIONAL TECHNICAL INFORMATION							
Screw holes distance	w x d	mm	See service manual				
Communication cable		mm ²	4 x 1,0	4 x 1,0	4 x 1,0		
Recommended power cable 11)		mm ²	Outdoor unit power supplied				
Recommended air switch		A	Outdoor unit power supplied				
EQUIPMENT							
Plasma generator			-	-	-		
Wifi module			-	-	-		
Drain pump			✓	✓	✓		
Max. lift (from bottom of ID unit)		mm	500	500	500		
Dry contact (ON/OFF)			✓	✓	✓		
Alarm contact			-	-	-		
Fresh air inlet			✓	✓	✓		
Decorative panel			✓	✓	✓		
STANDARD ACCESSORIES							
Standard health filter			-	-	-		
Remote controller (IR)			YT1F	YT1F	YT1F		
Wired controller			✓	✓	✓		
OPTIONAL ACCESSORIES							
Optional health filters			-				
Wired controller			SWC-02				
Central controller			SCC-16, SCC-36				
Other			G2S, G2S-T, SBG-01				

The specification of products is subject to change based on further development of the units by the producer and can be changed without prior notice. Refer to rating label.

R32 (single component refrigerant HFC), GWP of refrigerant used: 675. Contains fluorinated greenhouse gases covered by the Kyoto Protocol. Explanatory notes on the very last page of the catalogue.

These indoor units may be combined with other indoor units from MULTI VARIABLE series, it is essential to follow combinations recommended in the combination table.

APPEARANCE AND DIMENSIONS OF INDOOR UNIT

MV-C12BI2

MV-C18BI2

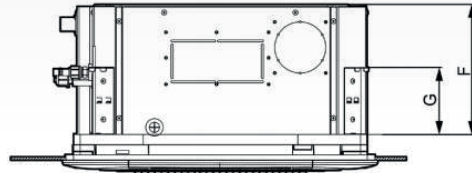
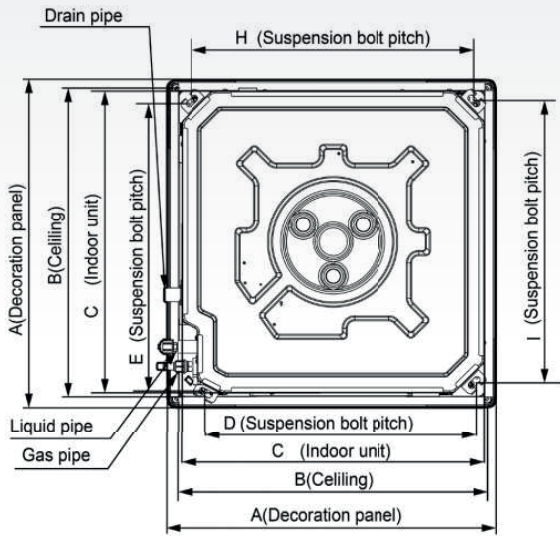

Model	A	B	C	D	E	F	G	H	I
MV-C12BI2	620	580	570	505	550	265	140	530	530
MV-C18BI2	620	580	570	505	550	265	140	530	530

units: mm

MV-C24BI2

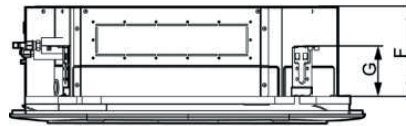
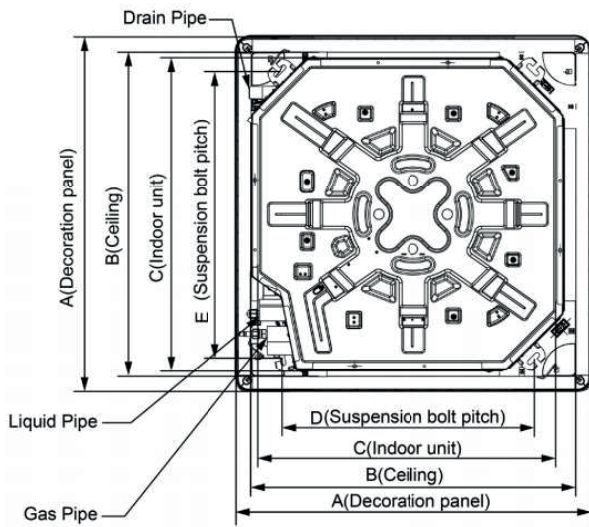

Model	A	B	C	D	E	F	G
MV-C24BI2	950	870	840	680	780	240	135

units: mm

CASSETTE INDOOR UNITS

MULTI VARIABLE SERIES

MODEL			MV-C12BI	MV-C18BI	MV-C24BI		
Capacity cooling/heating 1)	Nominal	kW	3,5 / 4,0	4,5 / 5	7,1 / 8		
Power supply		Hz / V	1~ / 50 / 220-240	1~ / 50 / 220-240	1~ / 50 / 220-240		
Airflow of ID	SH/H/M/L	m ³ / h	650 / 560 / 520 / 450	710 / 670 / 590 / 450	1280 / 1220 / 1100 / 880		
Sound pressure level of ID at 1,4m 4)	SH/H/M/L	dB(A)	44 / 41 / 38 / 34	47 / 45 / 41 / 35	47 / 45 / 41 / 36		
Sound power of ID 4)	SH/H/M/L	dB(A)	55 / 52 / 49 / 45	58 / 56 / 52 / 46	58 / 56 / 52 / 47		
External static pressure	nom/min-max	Pa	-	-	-		
Dehumidifying volume		l / h	1,4	1,8	2,5		
Refrigerant type		Type	R32	R32	R32		
Pipe diameter - liquid side 5)		inch / mm	¼ / 6,0	¼ / 6,0	¾ / 9,5		
Pipe diameter - gas side 5)		inch / mm	¾ / 9,5	¾ / 12,0	¾ / 16,0		
Dimension of ID	w x h x d	mm	596 x 240 x 596	596 x 240 x 596	840 x 240 x 840		
Dimension of panel	w x h x d	mm	670 x 50 x 670	670 x 50 x 670	950 x 60 x 950		
Package dimension of ID	w x h x d	mm	778 x 300 x 778	778 x 300 x 778	963 x 325 x 963		
Package dimension of panel	w x h x d	mm	763 x 105 x 763	763 x 105 x 763	1033 x 133 x 1038		
Weight of ID	net / gross	kg	20 / 24	20 / 24	26 / 32		
Weight of panel	net / gross	kg	3,5 / 5,0	3,5 / 5,0	7,0 / 11,0		
Set temperature range		°C	16 ~ 30	16 ~ 30	16 ~ 30		
ADDITIONAL TECHNICAL INFORMATION							
Screw holes distance	w x d	mm	See service manual				
Communication cable		mm ²	4 x 1,0	4 x 1,0	4 x 1,0		
Recommended power cable 11)		mm ²	Outdoor unit power supplied				
Recommended air switch		A	Outdoor unit power supplied				
EQUIPMENT							
Plasma generator			-	-	-		
Wifi module			-	-	-		
Drain pump			✓	✓	✓		
Max. lift (from bottom of ID unit)		mm	500	500	500		
Dry contact (ON/OFF)			✓	✓	✓		
Alarm contact			-	-	-		
Fresh air inlet			✓	✓	✓		
Decorative panel			✓	✓	✓		
STANDARD ACCESSORIES							
Standard health filter			-	-	-		
Remote controller (IR)			YT1F	YT1F	YT1F		
Wired controller			✓	✓	✓		
OPTIONAL ACCESSORIES							
Optional health filters			-				
Wired controller			SWC-02				
Central controller			SCC-16, SCC-36				
Other			G2S, G2S-T, SBG-01				

The specification of products is subject to change based on further development of the units by the producer and can be changed without prior notice. Refer to rating label.

R32 (single component refrigerant HFC), GWP of refrigerant used: 675. Contains fluorinated greenhouse gases covered by the Kyoto Protocol. Explanatory notes on the very last page of the catalogue.

These indoor units may be combined with other indoor units from MULTI VARIABLE series, it is essential to follow combinations recommended in the combination table.

APPEARANCE AND DIMENSIONS OF INDOOR UNIT

MV-C12BI

MV-C18BI

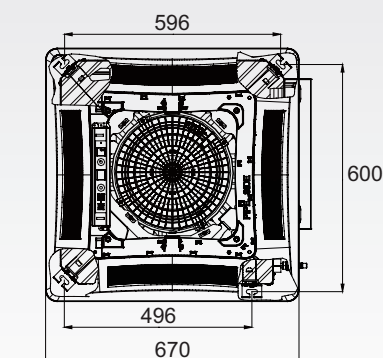

MV-C24BI

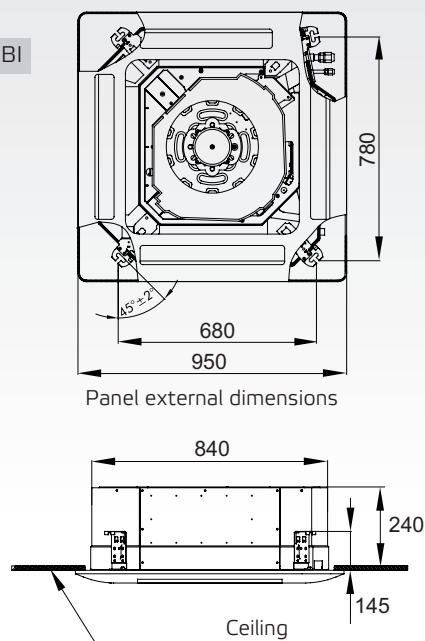

units: mm

DUCT INDOOR UNITS

MULTI VARIABLE SERIES

MODEL			MV-D09B12	MV-D12B12	MV-D18B12	MV-D24B12	
Capacity cooling/heating 1)	Nominal	kW	2,6 / 2,8	3,5 / 4,0	5 / 5,5	7,0 / 8	
Power supply		Hz / V	1~ / 50 / 220-240	1~ / 50 / 220-240	1~ / 50 / 220-240	1~ / 50 / 220-240	
Airflow of ID	SH/H/M/L	m ³ / h	560 / 450 / 340 / 220	600 / 540 / 420 / 300	800 / 720 / 610 / 420	1300 / 1200 / 1000 / 900	
Sound pressure level of ID at 1,4m 4)	SH/H/M/L	dB(A)	32 / 28 / 25 / 22	36 / 34 / 31 / 27	36 / 31 / 28 / 25	46 / 42 / 40 / 36	
Sound power of ID 4)	SH/H/M/L	dB(A)	47 / 43 / 40 / 37	51 / 49 / 46 / 42	51 / 46 / 43 / 40	61 / 57 / 55 / 51	
External static pressure	min-max	Pa	0-10	0-10	0-10	0-40	
Dehumidifying volume		l / h	0,8	1,4	1,8	2,5	
Refrigerant type		Type	R32	R32	R32	R32	
Pipe diameter - liquid side 5)		inch / mm	¼ / 6,0	¼ / 6,0	¼ / 6,0	¼ / 6,0	
Pipe diameter - gas side 5)		inch / mm	¾ / 9,5	¾ / 9,5	¾ / 12,0	¾ / 16,0	
Dimension of ID	w x h x d	mm	710 x 200 x 450	710 x 200 x 450	1010 x 200 x 450	900 x 260 x 655	
Dimension of panel	w x h x d	mm	-	-	-	-	
Package dimension of ID	w x h x d	mm	1008 x 275 x 568	1008 x 275 x 568	1308 x 275 x 568	1115 x 320 x 772	
Package dimension of panel	w x h x d	mm	-	-	-	-	
Weight of ID	net / gross	kg	18,5 / 22,5	19 / 23	25 / 30	31 / 36	
Weight of panel	net / gross	kg	-	-	-	-	
Set temperature range		°C	16 ~ 30	16 ~ 30	16 ~ 30	16 ~ 30	
ADDITIONAL TECHNICAL INFORMATION							
Screw holes distance	w x d	mm	742 x 491	742 x 491	942 x 491	1142 x 491	
Communication cable		mm ²	4 x 1,0	4 x 1,0	4 x 1,0	4 x 1,0	
Recommended power cable 11)		mm ²	Outdoor unit power supplied				
Recommended air switch		A	Outdoor unit power supplied				
EQUIPMENT							
Plasma generator			-	-	-	-	
Wifi module			-	-	-	-	
Drain pump			✓	✓	✓	✓	
Max. lift (from bottom of ID unit)		mm	1000	1000	1000	1000	
Dry contact (ON/OFF)			-	-	-	-	
Alarm contact			-	-	-	-	
Fresh air inlet			-	-	-	-	
STANDARD ACCESSORIES							
Standard health filter			-	-	-	-	
Remote controller (IR)			YT1F	YT1F	YT1F	YT1F	
Wired controller			✓	✓	✓	✓	
OPTIONAL ACCESSORIES							
Optional health filters			-				
Wired controller			SWC-02				
Central controller			SCC-16, SCC-36				
Other			G2S, G2S-T, SBG-01				

The specification of products is subject to change based on further development of the units by the producer and can be changed without prior notice. Refer to rating label.

R32 (single component refrigerant HFC), GWP of refrigerant used: 675. Contains fluorinated greenhouse gases covered by the Kyoto Protocol.

Explanatory notes on the very last page of the catalogue. These indoor units may be combined with other indoor units from MULTI VARIABLE series, it is essential to follow combinations recommended in the combination table.

APPEARANCE AND DIMENSIONS OF INDOOR UNIT

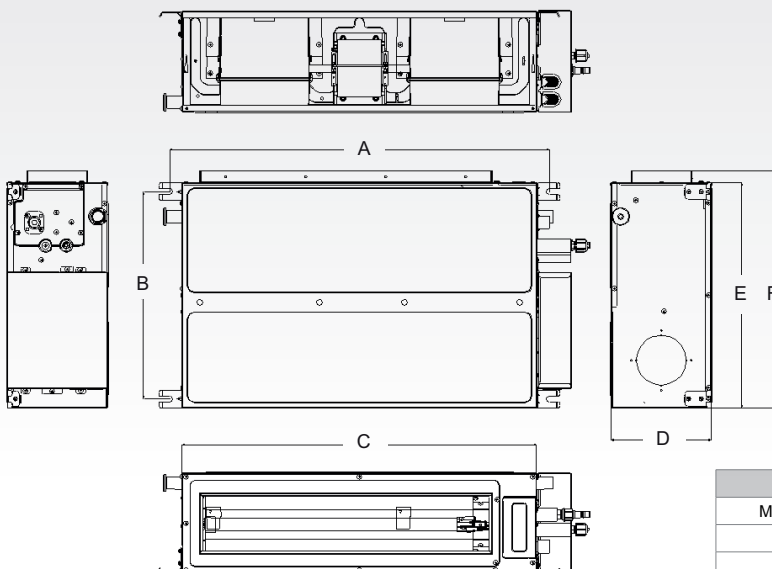

Model	A	B	C	D	E	F
MV-D09/12B12	760	415	710	200	450	474
MV-D18B12	1060	415	1010	200	450	474
MV-D24B12	942	530	900	260	655	685

DUCT INDOOR UNITS

MULTI VARIABLE SERIES

MODEL			MV-D09BI	MV-D12BI	MV-D18BI	MV-D24BI	
Capacity cooling/heating 1)	Nominal	kW	2,5 / 2,8	3,5 / 3,85	5 / 5,5	7,1 / 8	
Power supply		Hz / V	1~ / 50 / 220-240	1~ / 50 / 220-240	1~ / 50 / 220-240	1~ / 50 / 220-240	
Airflow of ID	SH/H/M/L	m ³ / h	450 / 350 / 280	550 / 400 / 300	700 / 600 / 500	1000 / 750 / 550	
Sound pressure level of ID at 1,4m 4)	SH/H/M/L	dB(A)	47 / 41 / 37 / 34 / 31	49 / 42 / 39 / 35 / 32	51 / 43 / 41 / 33 / -	52 / 44 / 42 / 34 / -	
Sound power of ID 4)	SH/H/M/L	dB(A)	57 / 51 / 47 / 44 / 41	59 / 52 / 49 / 45 / 42	61 / 53 / 51 / 43 / -	62 / 55 / 52 / 44 / -	
External static pressure	nom/min-max	Pa	25 / 0-50	25 / 0-50	25 / 0-50	25 / 0-50	
Dehumidifying volume		l / h	0,8	1,4	1,8	2,5	
Refrigerant type		Type	R32	R32	R32	R32	
Pipe diameter - liquid side 5)		inch / mm	¼ / 6,0	¼ / 6,0	¼ / 6,0	¾ / 9,5	
Pipe diameter - gas side 5)		inch / mm	¾ / 9,5	¾ / 9,5	¾ / 12,0	¾ / 16,0	
Dimension of ID	w x h x d	mm	700 x 200 x 615	700 x 200 x 615	900 x 200 x 615	1100 x 200 x 615	
Dimension of panel	w x h x d	mm	-	-	-	-	
Package dimension of ID	w x h x d	mm	893 x 305 x 743	893 x 305 x 743	1123 x 305 x 743	1323 x 305 x 743	
Package dimension of panel	w x h x d	mm	-	-	-	-	
Weight of ID	net / gross	kg	21 / 26	22 / 28	26 / 32	30 / 40	
Weight of panel	net / gross	kg	-	-	-	-	
Set temperature range		°C	16 ~ 30	16 ~ 30	16 ~ 30	16 ~ 30	
ADDITIONAL TECHNICAL INFORMATION							
Screw holes distance	w x d	mm	742 x 491	742 x 491	942 x 491	1142 x 491	
Communication cable		mm ²	4 x 1,0	4 x 1,0	4 x 1,0	4 x 1,0	
Recommended power cable 11)		mm ²	Outdoor unit power supplied				
Recommended air switch		A	Outdoor unit power supplied				
EQUIPMENT							
Plasma generator			-	-	-	-	
Wifi module			-	-	-	-	
Drain pump			✓	✓	✓	✓	
Max. lift (from bottom of ID unit)		mm	1000	1000	1000	1000	
Dry contact (DN/OFF)			-	-	-	-	
Alarm contact			-	-	-	-	
Fresh air inlet			-	-	-	-	
STANDARD ACCESSORIES							
Standard health filter			-	-	-	-	
Remote controller (IR)			YT1F	YT1F	YT1F	YT1F	
Wired controller			✓	✓	✓	✓	
OPTIONAL ACCESSORIES							
Optional health filters			-				
Wired controller			SWC-02				
Central controller			SCC-16, SCC-36				
Other			G2S, G2S-T, SBG-01				

The specification of products is subject to change based on further development of the units by the producer and can be changed without prior notice. Refer to rating label.

R32 (single component refrigerant HFC), GWP of refrigerant used: 675. Contains fluorinated greenhouse gases covered by the Kyoto Protocol.

Explanatory notes on the very last page of the catalogue. These indoor units may be combined with other indoor units from MULTI VARIABLE series, it is essential to follow combinations recommended in the combination table.

APPEARANCE AND DIMENSIONS OF INDOOR UNIT

	A	B	C	D	E	F	G	H	I	J
MV-D09BI	742	491	662	620	700	615	782	156	200	635
MV-D12BI	942	491	862	820	900	615	982	156	200	635
MV-D18BI	1142	491	1062	1020	1100	615	1182	156	200	635
AIR OUTLET / AIR INLET	A	B	C	D						
MV-D09BI	156	662	580	162						
MV-D12BI	156	662	580	162						
MV-D18BI	156	862	780	162						
MV-D24BI	156	1062	980	162						

units: mm

OUTDOOR UNITS

MULTI VARIABLE SERIES

MODEL			MV-E14BI2	MV-E18BI2	MV-E21BI2	MV-E24BI2	MV-E28BI2
Qty of connectable indoor units			1-2	1-2	2-3	2-3	2-4
Capacity cooling/heating 1)	Nominal (min-max)	kW	4,1 (2,1-4,4) / 4,4(2,5-5,4)	5,3 (2,1-5,8) / 5,6 (2,6-6,0)	6,1 (2,2-7,3) / 6,5 (3,6-8,5)	7,1 (2,3-8,5) / 8,6 (3,7-8,8)	8,0 (2,3-10,3) / 9,5 (3,7-10,3)
Power supply		Hz / V	1~ / 50 / 220-240	1~ / 50 / 220-240	1~ / 50 / 220-240	1~ / 50 / 220-240	1~ / 50 / 220-240
Power input cooling/heating 1)		W	1100 / 970	1480 / 1250	1480 / 1430	1880 / 2230	2120 / 2200
Maximal power input 2)		W	2250	2500	2900	3400	3600
Power current cooling/heating		A	4,88 / 4,44	6,56 / 5,55	6,57 / 6,33	8,35 / 9,89	9,41 / 9,77
Maximal power current 2)		A	10,0	11,0	12,9	14,6	15,9
Energy class cooling 3)		-	-	-	-	-	-
Airflow of OD	H	m ³ / h	2300	2300	3800	3800	3800
Sound pressure level of OD at 1m 4)	H	dB(A)	52	54	58	58	58
Sound power of OD 4)	H	dB(A)	62	64	68	68	68
Refrigerant type/charge		Type / kg / t eq. CO ₂	R32 / 0,75 / 0,51	R32 / 0,90 / 0,60	R32 / 1,60 / 1,08	R32 / 1,70 / 1,14	R32 / 1,80 / 1,21
Additional refrigerant		g / m	20	20	20	20	20
Pipe diameter - liquid side 5)		qty x mm	2 x 6,0	2 x 6,0	3 x 6,0	3 x 6,0	4 x 6,0
Pipe diameter - gas side 5)		qty x mm	2 x 9,5	2 x 9,5	3 x 9,5	3 x 9,5	4 x 9,5
Max pipe length without additional refrigerant 6)		m	10	10	30	30	40
Maximal pipe length to 1 indoor unit 9)		m	20	20	20	20	20
Maximal total pipe length 7)		m	40	40	60	60	70
Max. elevation/ Drop height		m	15	15	15	15	15
Dimension of OD	w x h x d	mm	822 x 550 x 352	822 x 550 x 352	964 x 660 x 402	964 x 660 x 402	964 x 660 x 402
Package dimension of OD	w x h x d	mm	872 x 620 x 398	872 x 620 x 398	1032 x 737 x 456	1032 x 737 x 456	1032 x 737 x 456
Weight of OD	net / gross	kg	30,0 / 32,5	32,0 / 34,5	47,5 / 52,0	47,5 / 52,0	51,0 / 55,5
Operating temperature range 8)	Cooling	°C	-15 ~ 43	-15 ~ 43	-15 ~ 43	-15 ~ 43	-15 ~ 43
	Heating	°C	-22 ~ 24	-22 ~ 24	-22 ~ 24	-22 ~ 24	-22 ~ 24
ADDITIONAL TECHNICAL INFORMATION							
Screw holes distance of OD	w x d	mm	512 x 332	512 x 332	570 x 371	570 x 371	570 x 371
Communication cable		mm ²			4 x 1,5		
Recommended power cable		mm ²	3 x 1,5	3 x 1,5	3 x 2,5	3 x 2,5	3 x 4,0
Recommended air switch		A	13	16	16	16	20
EQUIPMENT							
Throttling method			EXV	EXV	EXV	EXV	EXV
Bottom chassis heater			Heating belt	Heating belt	Heating belt	Heating belt	Heating belt
Crankcase heater			✓	✓	✓	✓	✓
Bottom plugs for OD			✓	✓	✓	✓	✓
Drain pipe connector			✓	✓	✓	✓	✓
Pipe reduction			✓	✓	✓	✓	✓

The specification of products is subject to change based on further development of the units by the producer and can be changed without prior notice. Refer to rating label.

R32 (single component refrigerant HFC), GWP of refrigerant used: 675. Contains fluorinated greenhouse gases covered by the Kyoto Protocol.

Explanatory notes on the very last page of the catalogue. May not be used separately, must be combined with indoor units from Multi Variable (MV) series.

APPEARANCE AND DIMENSIONS OF INDOOR UNIT

MV-E14BI2, MV-E18BI2

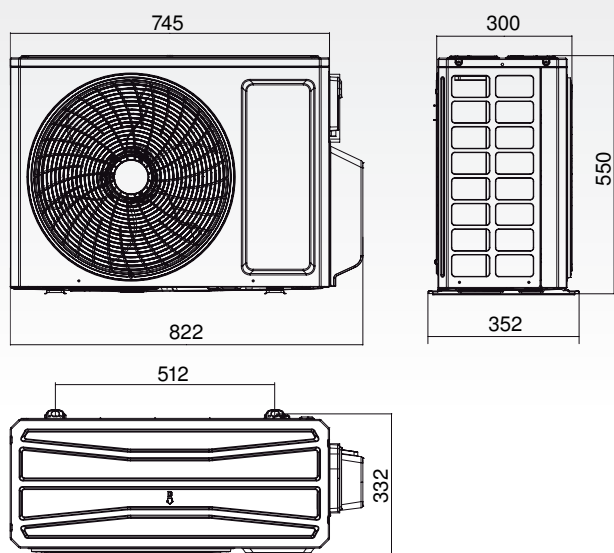

MV-E21BI2, MV-E24BI2, MV-E28BI2

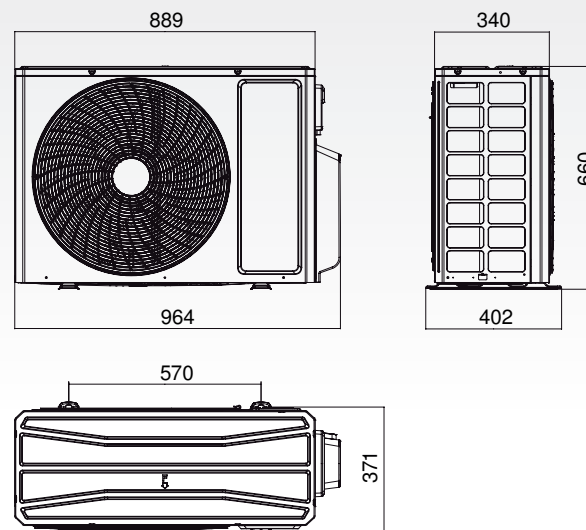

units: mm

OUTDOOR UNITS

MULTI VARIABLE SERIES

MODEL			MV-E14BI	MV-E18BI	MV-E21BI	MV-E24BI	
Qty of connectable indoor units			1-2	1-2	2-3	2-3	
Capacity cooling/heating 1)	Nominal (min-max)	kW	4,1 (2,1-4,4) / 4,4 (2,5-5,4)	5,2 (2,1-5,8) / 5,4 (2,6-5,9)	6,1 (2,2-7,3) / 6,5 (3,6-8,5)	7,1 (2,3-8,5) / 8,5 (3,7-8,8)	
Power supply		Hz / V	1~ / 50 / 220-240	1~ / 50 / 220-240	1~ / 50 / 220-240	1~ / 50 / 220-240	
Power input cooling/heating 1)		W	1200 / 1180	1450 / 1300	1740 / 1600	2180 / 2280	
Maximal power input 2)		W	1780	1780	2870	2870	
Power current cooling/heating		A	5,32 / 4,53	6,43 / 5,77	7,72 / 7,10	9,67 / 10,12	
Maximal power current 2)		A	7,9	7,9	12,7	12,7	
Energy class cooling 3)		-	See table below	See table below	See table below	See table below	
Airflow of OD	H	m ³ / h	2600	2600	3200	4000	
Sound pressure level of OD at 1m 4)	H	dB(A)	55	55	58	58	
Sound power of OD 4)	H	dB(A)	65	65	68	68	
Refrigerant type/charge		Type / kg / t eq. CO ₂	R32 / 1,05 / 0,71	R32 / 1,05 / 0,71	R32 / 1,60 / 1,08	R32 / 1,80 / 1,22	
Additional refrigerant		g / m	20	20	20	20	
Pipe diameter - liquid side 5)		qty x mm	2 x 6,0	2 x 6,0	3 x 6,0	3 x 6,0	
Pipe diameter - gas side 5)		qty x mm	2 x 9,5	2 x 9,5	3 x 9,5	3 x 9,5	
Max pipe length without additional refrigerant 6)		m	10	10	30	30	
Maximal pipe length to 1 indoor unit 9)		m	10	10	20	20	
Maximal total pipe length 7)		m	20	20	60	60	
Max. elevation/ Drop height		m	5	5	10	10	
Dimension of OD	w x h x d	mm	899 x 596 x 378	899 x 596 x 378	963 x 700 x 396	1001 x 790 x 427	
Package dimension of OD	w x h x d	mm	948 x 645 x 420	948 x 645 x 420	1029 x 750 x 458	1038 x 855 x 488	
Weight of OD	net / gross	kg	43,0 / 46,0	43,0 / 46,0	55,0 / 59,5	68,0 / 73,0	
Operating temperature range 8)	Cooling	°C	- 15 ~ 43	- 15 ~ 43	- 15 ~ 43	- 15 ~ 43	
	Heating	°C	- 20 ~ 24	- 20 ~ 24	- 20 ~ 24	- 20 ~ 24	
ADDITIONAL TECHNICAL INFORMATION							
Screw holes distance of OD	w x d	mm	550 x 354	550 x 354	560 x 368	610 x 399	
Communication cable		mm ²	4 x 1,5				
Recommended power cable		mm ²	3 x 1,5	3 x 1,5	3 x 2,5	3 x 2,5	
Recommended air switch		A	13	13	16	16	
EQUIPMENT							
Throttling method			EXV	EXV	EXV	EXV	
Bottom chassis heater			Heating belt	Heating belt	Heating belt	Heating belt	
Crankcase heater			✓	✓	✓	✓	
Bottom plugs for OD			✓	✓	✓	✓	
Drain pipe connector			✓	✓	✓	✓	
Pipe reduction			✓	✓	✓	✓	

The specification of products is subject to change based on further development of the units by the producer and can be changed without prior notice. Refer to rating label.

R32 (single component refrigerant HFC), GWP of refrigerant used: 675.

Contains fluorinated greenhouse gases covered by the Kyoto Protocol.

Explanatory notes on the very last page of the catalogue.

May not be used separately, must be combined with indoor units from Multi Variable (MV) series.

OUTDOOR UNITS

MULTI VARIABLE SERIES

MODEL			MV-E28BI	MV-E36BI	MV-E42BI		
Qty of connectable indoor units			2-4	2-4	2-5		
Capacity cooling/heating 1)	Nominal (min-max)	kW	8,0 (2,3-10,3) / 9,5 (3,7-10,3)	10,5 (2,1-11,0) / 12,0 (2,6-13,0)	12,1 (2,1-13,6) / 13,0 (2,6-14,0)		
Power supply		Hz / V	1~ / 50 / 220-240	1~ / 50 / 220-240	1~ / 50 / 220-240		
Power input cooling/heating 1)		W	2540 / 2490	3500 / 3750	3590 / 3550		
Maximal power input 2)		W	3580	4880	5300		
Power current cooling/heating		A	15,71 / 11,05	15,42 / 15,20	16,43 / 16,22		
Maximal power current 2)		A	15,9	20,0	20,0		
Energy class cooling 3)		-	See table below	See table below	See table below		
Airflow of OD	H	m ³ / h	4000	7200	7200		
Sound pressure level of OD at 1m 4)	H	dB(A)	58	60	60		
Sound power of OD 4)	H	dB(A)	68	70	70		
Refrigerant type/charge		Type / kg / t eq. CO ₂	R32 / 2,00 / 1,35	R32 / 2,75 / 1,86	R32 / 2,75 / 1,86		
Additional refrigerant		g / m	20	20	20		
Pipe diameter - liquid side 5)		qty x mm	4 x 6,0	4 x 6,0	5 x 6,0		
Pipe diameter - gas side 5)		qty x mm	4 x 9,5	4 x 9,5	5 x 9,5		
Max pipe length without additional refrigerant 6)		m	40	40	40		
Maximal pipe length to 1 indoor unit 9)		m	20	25	25		
Maximal total pipe length 7)		m	70	75	75		
Max. elevation/ Drop height		m	10	15	15		
Dimension of OD	w x h x d	mm	1001 x 790 x 427	1098 x 1106 x 440	1098 x 1106 x 440		
Package dimension of OD	w x h x d	mm	1083 x 855 x 488	1158 x 1235 x 493	1158 x 1235 x 493		
Weight of OD	net / gross	kg	69,0 / 74,0	90,0 / 98,0	90,0 / 98,0		
Operating temperature range 8)	Cooling	°C	- 15 ~ 43	- 15 ~ 43	- 15 ~ 43		
	Heating	°C	- 20 ~ 24	- 20 ~ 24	- 20 ~ 24		
ADDITIONAL TECHNICAL INFORMATION							
Screw holes distance of OD	w x d	mm	610 x 399	631 x 401	631 x 401		
Communication cable		mm ²		4 x 1,5			
Recommended power cable		mm ²	3 x 4,0	3 x 4,0	3 x 4,0		
Recommended air switch		A	20	25	25		
EQUIPMENT							
Throttling method			EXV	EXV	EXV		
Bottom chassis heater			Heating belt	Heating belt	Heating belt		
Crankcase heater			✓	✓	✓		
Bottom plugs for OD			✓	✓	✓		
Drain pipe connector			✓	✓	✓		
Pipe reduction			✓	✓	✓		

The specification of products is subject to change based on further development of the units by the producer and can be changed without prior notice. Refer to rating label.

R32 (single component refrigerant HFC), GWP of refrigerant used: 675.

Contains fluorinated greenhouse gases covered by the Kyoto Protocol.

Explanatory notes on the very last page of the catalogue.

May not be used separately, must be combined with indoor units from Multi Variable (MV) series.

	6 mm → 10 mm	10 mm → 12 mm	10 mm → 16 mm		
MV-E14,18BI	-	1 x	-		
MV-E21,24,28BI	-	2 x	-		
MV-E36BI	2 x	4 x	2 x		
MV-E42BI	2 x	4 x	3 x		

OUTDOOR UNITS

MULTI VARIABLE SERIES

ENERGY CLASS INFORMATION

COOLING						
Outdoor unit	Indoor unit	Energy class	Pdesign cooling (kW)	SEER	Annual power consumption (kWh/a)	
MV-E14BI	2 x MV-H07BIF	A++	4,1	6,1	235	
MV-E18BI	2 x MV-H09BIF	A++	5,2	6,1	298	
MV-E21BI	3 x MV-H07BIF	A++	6,1	6,1	350	
MV-E24BI	2 x MV-H09BIF, MV-H07BIF	A++	7,1	6,1	407	
MV-E28BI	4 x MV-H07BIF	A++	8,0	6,1	459	
MV-E36BI	4 x MV-H09BIF	A++	10,5	6,1	602	
MV-E42BI	4 x MV-H09BIF, MV-H07BIF	A++	12,0	6,1	689	
HEATING-AVERAGE CLIMATE						
Outdoor unit	Indoor unit	Energy class	Pdesign heating (kW)	SCOP	Annual power consumption (kWh/a)	
MV-E14BI	2 x MV-H07BIF	A+	3,8	4,0	1330	
MV-E18BI	2 x MV-H09BIF	A+	3,8	4,0	1330	
MV-E21BI	3 x MV-H07BIF	A+	6,1	4,0	2135	
MV-E24BI	2 x MV-H09BIF, MV-H07BIF	A+	6,1	4,0	2135	
MV-E28BI	4 x MV-H07BIF	A+	7,2	4,0	2520	
MV-E36BI	4 x MV-H09BIF	A+	10,5	4,0	3675	
MV-E42BI	4 x MV-H09BIF, MV-H07BIF	A+	11,8	4,0	4130	

APPEARANCE AND DIMENSIONS OF OUTDOOR UNIT

MV-E14BI, MV-E18BI

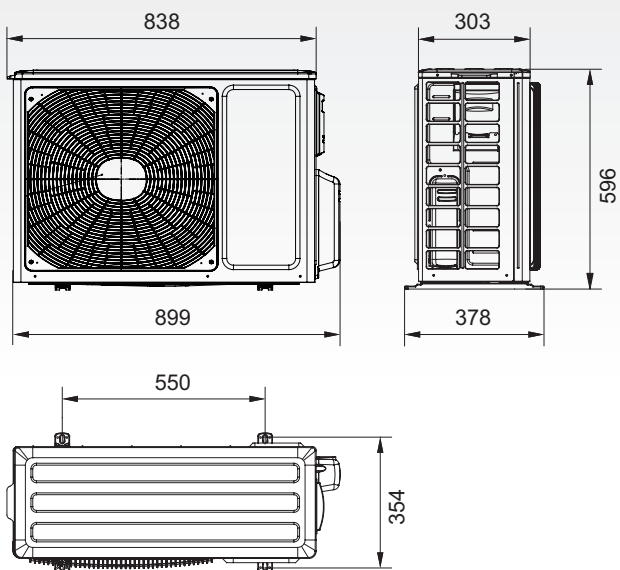

MV-E21BI

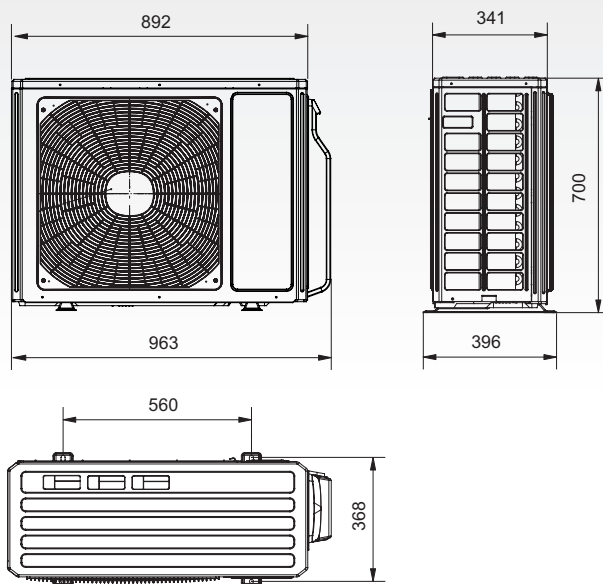

MV-E24BI, MV-E28BI

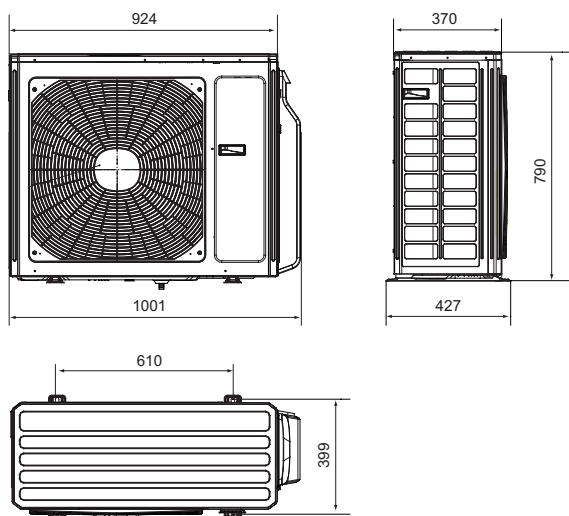

MV-E36BI, MV-E42BI

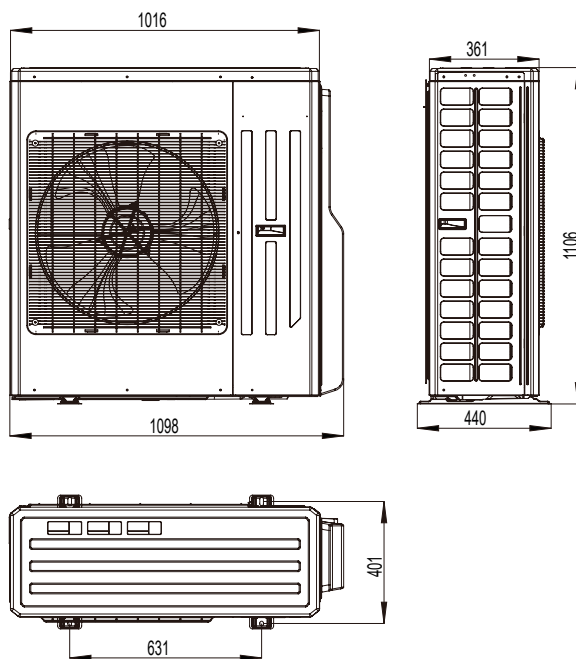

units: mm

ELECTRICAL WIRING DIAGRAM

MULTI VARIABLE SERIES

MV-E14BI, MV-E18BI

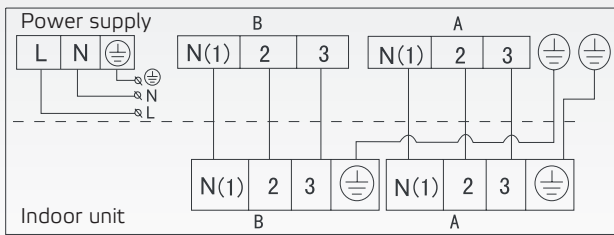

MV-E21BI

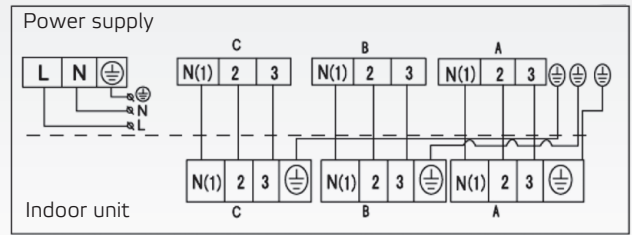

MV-E24BI

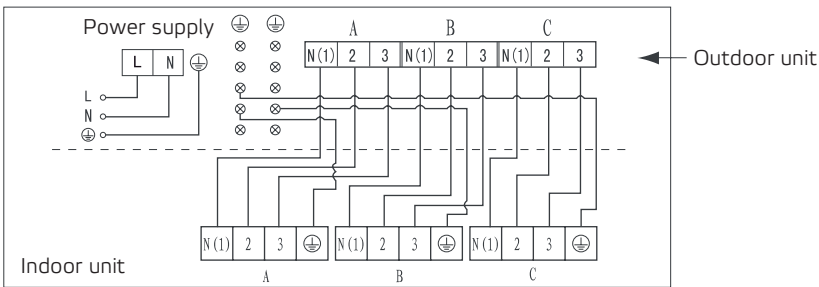

MV-E28BI

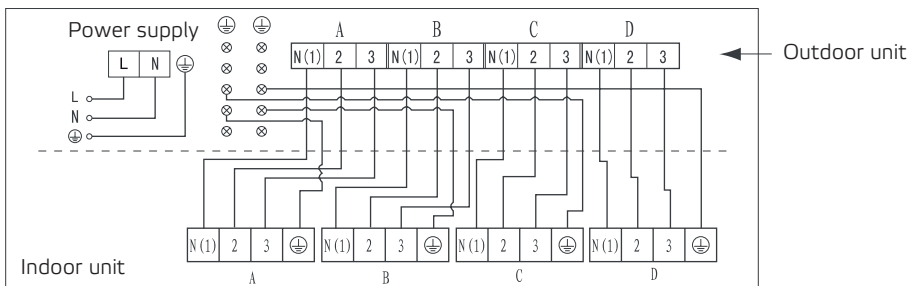

MV-E36BI

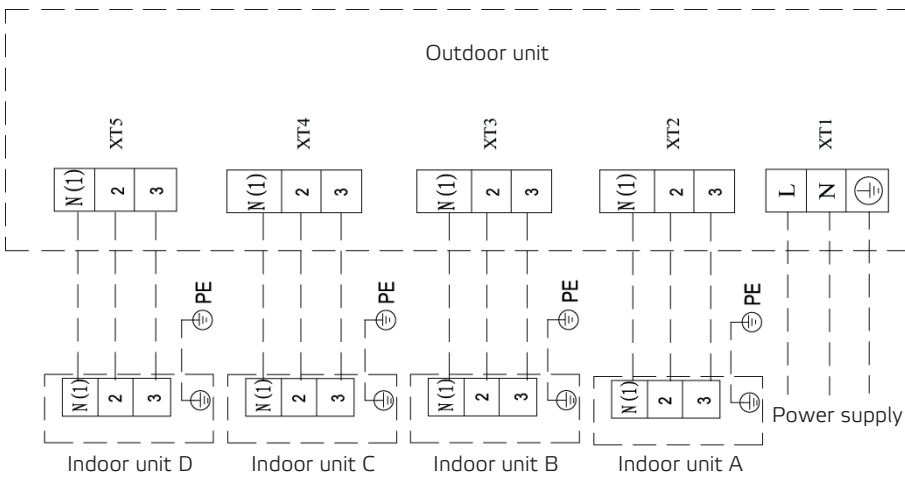

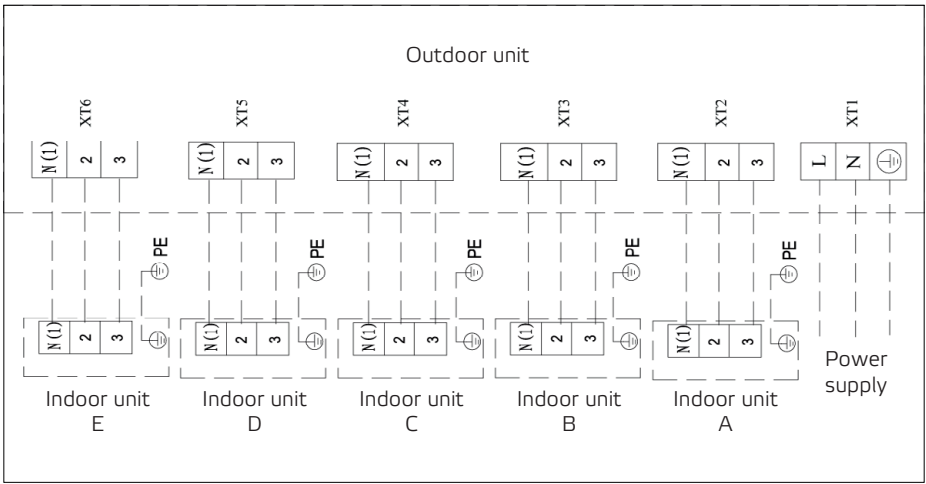

OUTDOOR UNITS

MULTI VARIABLE SERIES

COMBINATION TABLES

(unit: x1000Btu/h)

MV-E14BI		MV-E21BI		MV-E24BI			MV-E28BI
1 UNIT	2 UNITS	2 UNITS	3 UNITS	2 UNITS	3 UNITS		2 UNITS
7	7+7	7+7	7+7+7	7+7	7+7+7	7+7+18	7+7
9	7+12	7+12	7+7+12	7+12	9+9+12	7+9+18	7+12
12	7+9	9+9	7+7+9	9+9	7+7+9	12+12+12*	9+9
	9+9	7+9	7+9+9	9+18	7+9+9	7+12+12	9+18
	9+12	7+18	9+9+9	12+18	7+7+12	9+9+18*	12+18
		9+12	7+9+12	7+9	7+9+12	9+12+12*	7+9
MV-E18BI							
1 UNIT	2 UNITS	9+18	7+12+12	7+18	9+9+9		7+18
7	7+7	12+12	9+9+12	9+12			9+12
9	7+12	12+18	12+12+12*	12+12			12+12
12	9+12			18+18			18+18
	7+9						
	9+9						
MV-E28BI		MV-E36BI					
3 UNITS		4 UNITS	2 UNITS		3 UNITS		
7+7+7	7+12+18	7+7+7+7	7+7	9+24	7+7+7	7+12+18	9+12+18
7+7+9	9+9+9	7+7+7+9	7+9	12+12	7+7+9	7+12+24	9+12+24
7+7+12	9+9+12	7+7+9+9	7+12	12+18	7+7+12	7+18+18	9+18+18
7+7+18	9+9+18	9+9+9+9	7+18	12+24	7+7+18	7+18+24*	9+18+24*
7+9+9	9+12+18	7+7+7+12	7+24	18+18	7+7+24	9+9+9	12+12+12
7+9+12	9+12+12	7+7+9+12	9+9	18+24	7+9+9	9+9+12	12+12+18
7+9+18	12+12+12	7+9+9+9	9+12	24+24*	7+9+12	9+9+18	12+12+24
7+12+12	12+12+18	7+7+7+18	9+18		7+9+18	9+9+24	12+18+18
		7+7+9+18			7+9+24	9+12+12	18+18+18*
		7+9+9+12			7+12+12		
		9+9+12+12					
		7+7+12+12					
		9+9+9+12					
MV-E36BI		MV-E42BI					
4 UNITS		2 UNITS		3 UNITS			
7+7+7+7	7+7+18+18*	9+9+9+9	7+7	9+24	7+7+7	7+12+24	9+18+18
7+7+7+9	7+9+9+9	9+9+9+12	7+9	12+12	7+7+9	7+18+18	9+18+24
7+7+7+12	7+9+9+12	9+9+9+18	7+12	12+18	7+7+12	7+18+24	9+24+24
7+7+7+18	7+9+9+18	9+9+12+12	7+18	12+24	7+7+18	7+24+24	12+12+12
7+7+7+24	7+9+9+24*	9+12+12+12	7+24	18+18	7+7+24	9+9+9	12+12+18
7+7+9+9	7+9+12+12	9+9+9+24*	9+9	18+24	7+9+9	9+9+12	12+12+24
7+7+9+12	7+9+12+18	9+9+12+18	9+12	24+24	7+9+12	9+9+18	12+18+18
7+7+9+18	7+9+18+18*	9+9+18+18*	9+18		7+9+18	9+9+24	12+18+24
7+7+9+24	7+12+12+12	9+12+12+18*			7+9+24	9+12+12	18+18+18
7+7+12+12	7+12+12+18	12+12+12+12			7+12+12	9+12+18	12+24+24*
7+7+12+18					7+12+18	9+12+24	18+18+24
7+7+12+24							
MV-E42BI		MV-E48BI					
4 UNITS		5 UNITS					
7+7+7+7	7+7+18+18	9+9+9+12	7+9+18+24	7+7+7+7+7	7+7+9+9+12	9+9+9+9+18	7+9+9+12+18
7+7+7+9	7+9+9+9	9+9+9+18	7+12+12+24	7+7+7+7+9	7+7+9+9+18	9+9+9+12+12	7+9+9+12+24*
7+7+7+12	7+9+9+12	9+9+9+24	7+12+18+18	7+7+7+7+12	7+7+9+12+12	9+9+12+12+12	7+9+9+18+18
7+7+7+18	7+9+9+18	9+9+12+12	7+12+18+24	7+7+7+7+18	7+7+9+12+18	9+9+12+12+18*	7+9+12+12+18
7+7+7+24	7+9+9+24	9+9+12+18	7+18+18+18	7+7+7+7+24	7+7+12+12+12	7+7+7+12+24	7+12+12+12+12
7+7+9+9	7+9+12+12	9+9+12+24	9+9+18+24	7+7+7+9+9	7+9+9+9+9	7+7+7+18+18	7+12+12+12+18
7+7+9+12	7+9+12+18	9+9+18+18	9+12+12+24	7+7+7+9+12	7+9+9+9+12	7+7+9+9+24	9+9+9+9+24
7+7+9+18	7+9+12+24*	9+12+12+12*	9+12+18+18	7+7+7+9+18	7+9+9+9+18	7+7+9+12+24	9+9+9+12+18
7+7+9+24	7+9+18+18	9+12+12+18	9+18+18+18	7+7+7+9+24	7+9+9+12+12	7+7+9+18+18	9+9+9+18+18*
7+7+12+12	7+12+12+12	12+12+12+12	12+12+18+18	7+7+7+12+12	7+9+12+12+12	7+7+12+12+18	9+12+12+12+12
7+7+12+18	7+12+12+18	12+12+12+18	12+12+12+24	7+7+7+12+18	9+9+9+9+9	7+7+12+18+18	9+12+12+12+18*
7+7+12+24	9+9+9+9	7+7+18+24		7+7+9+9+9	9+9+9+9+12	7+9+9+9+24	12+12+12+12+12

*This combinations of indoor units capacities exceed 130% of maximum capacity of the outdoor unit. The table is also valid for the newer outdoor units MV-ExxBI2

OUTDOOR UNITS

HIGH POWER MULTI SYSTEM SERIES

MODEL			MS-E48AIN	MS-E56AIN		
Qty of connectable indoor units		-	2-8	2-9		
Capacity cooling/heating 1)	Nominal (min-max)	kW	14,0 (1,0-16,0) / 16,0 (1,2-17,4)	16,0 (1,0-18,0) / 18,0 (1,2-19,0)		
Power supply		Hz / V	3~ / 50 / 380-415	3~ / 50 / 380-415		
Power input cooling/heating 1)		W	4600 / 4250	5200 / 4700		
Maximal power input 2)		W	6000	6500		
Power current cooling/heating		A	9,0 / 8,4	9,5 / 8,5		
Maximal power current 2)		A	12	12		
EER/COP 10)		-	2,7 / 3,2	2,65 / 3,5		
Airflow	V	m ³ / h	7000	7000		
Sound pressure 4)	V	dB(A)	58	58		
Sound power 4)	V	dB(A)	68	68		
Refrigerant type/charge		Type / kg / t eq. CO ₂	R410A / 4,95 / 10,33	R410A / 4,95 / 10,33		
Additional refrigerant		g / m	depend on calculation	depend on calculation		
Pipe diameter - liquid side 5)		inch / mm	¾ / 9,5	¾ / 9,5		
Pipe diameter - gas side 5)		inch / mm	¾ / 15,9	¾ / 19,1		
Max pipe length without additional refrigerant 6)		m	30	30		
Max. total pipe length (ΣL+ΣA) 7)		m	135	145		
Max. total pipe length between OD and Dbox (ΣL)		m	55	55		
Max. total pipe length between Dbox and ID (ΣA)		m	80	90		
Pipe length between Dbox and ID (A1,2,...)		m	15	15		
Max. height between OD and Dbox (H1) and ID (H2)		m	30	30		
Max. height between DBoxes or IDs (H3)		m	15	15		
Dimension of ID	w x h x d	mm	900 x 1345 x 340	900 x 1345 x 340		
Package dimension of ID	w x h x d	mm	993 x 1500 x 453	993 x 1500 x 453		
Weight of ID	net / gross	kg	116 / 125	116 / 125		
Operating temperature range cooling 8)		°C	18-48	18-48		
Operating temperature range heating 8)		°C	-10-24	-10-24		

ADDITIONAL TECHNICAL INFORMATION

Screw holes distance of OD	w x d	mm	572 x 378	572 x 378		
Communication cable		mm ²	2 x 1,5	2 x 1,5		
Recommended power cable		mm ²	5 x 4,0	5 x 4,0		
Recommended air switch		A	20	20		

EQUIPMENT

Throttling method			-	-		
Bottom chassis heater			-	-		
Crankcase heater			Heating belt	Heating belt		
Bottom plugs for OD			✓	✓		
Drain pipe connector			✓	✓		
Pipe reduction			✓	✓		

The specification of products is subject to change based on further development of the units by the producer and can be changed without prior notice. Refer to rating label.

R410A (50% HFC-32, 50% HFC-125), GWP 2088

Contains fluorinated greenhouse gases covered by the Kyoto Protocol.

Explanatory notes on the very last page of the catalogue.

May not be used separately, must be combined with indoor units from multi split series (MV, MS, MC). For using 2-3 distribution boxes in one system it is necessary to use MS-01BI joints.

DISTRIBUTION BOXES

MODEL			DB2-195B	DB3-195B	DB5-16AF
Maximum number of connectable indoor units		-	2	3	5
Power Supply		Hz / V	1~ / 50 / 220-240	1~ / 50 / 220-240	1~ / 50 / 220-240
Connection port to outdoor unit liquid / gas		mm	9,52 (3/8") + 19,1 (3/4")	9,52 (3/8") + 19,1 (3/4")	9,52 (3/8") + 15,9 (5/8")
Connection port to indoor unit liquid / gas		mm	2 x 6,35 (1/4") + 15,9 (5/8")	3 x 6,35 (1/4") + 15,9 (5/8")	5 x 6,35 (1/4") + 9,52 (3/8")
Connection Method		-	braze	braze	flare
Sound pressure level 4)		dB(A)	28	28	30
Sound power level 4)		dB(A)	-	-	-
Unit dimensions	w x h x d	mm	600 x 313 x 182	600 x 313 x 182	617 x 410 x 193
Package dimensions	w x h x d	mm	683 x 392 x 270	683 x 392 x 270	676 x 473 x 275
Weight	net / gross	kg	5,5 / 7,5	6,0 / 8,0	9,0 / 11,0

ADDITIONAL TECHNICAL INFORMATION

Screw holes distance	w x d	mm	383 x 263	383 x 263	463 x 338
Communication cable		mm ²	2 x 1,5	2 x 1,5	2 x 1,5
Recommended power cable		mm ²	3 x 1,5	3 x 1,5	3 x 1,5
Recommended air switch		A	10	10	10

DISTRIBUTION BOXES ADDRESS SETTINGS

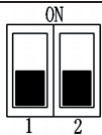
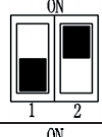
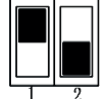
Position	Address
	Distribution box 1
	Distribution box 2
	Distribution box 3

For using 2-3 distribution boxes in one system it is necessary to use MS-01BI joints.

ALLOWED LENGTH AND DROP HEIGHT OF CONNECTION PIPE
HIGH POWER MULTI SYSTEM SERIES

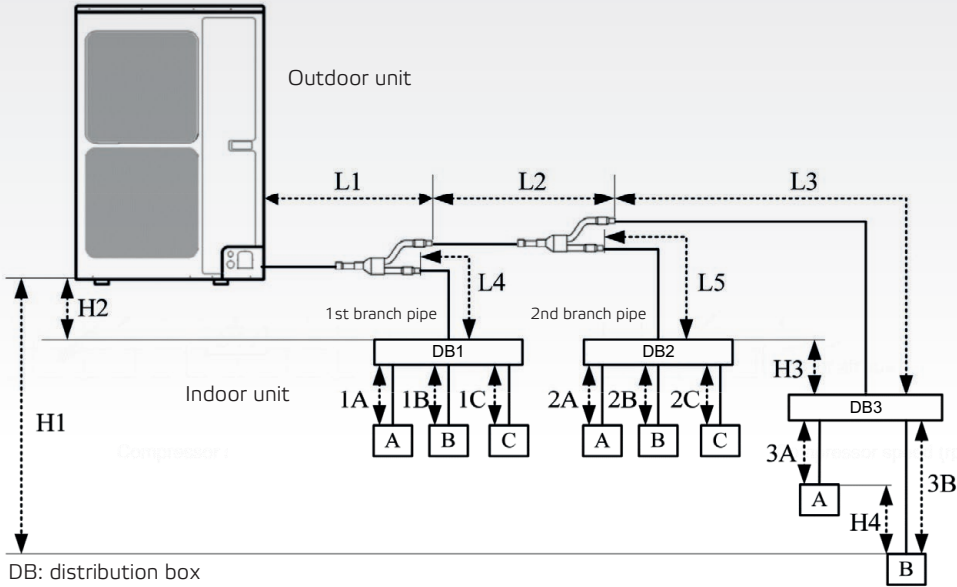

MAXIMUM LENGTH OF CONNECTION PIPES

		The pipes	Length (m)
Maximal allowed length	Total length between outdoor unit and distribution boxes	L1+L2+L3+L4+L5	≤ 55
	Total length between indoor unit and distribution box	MS-E48AIN	≤ 80
		MS-E56AIN	≤ 90
	Between indoor unit and distribution box	1A; 1B; 1C; 2A; 2B; 2C; 3A; 3B	≤ 15
Maximal allowed length	Between indoor unit and the 1st branch	L4+1B; L2+L5+2A; L2+L3+3B	≤ 40
	Between outdoor unit and indoor units	H1	≤ 30
	Between outdoor unit and distribution box	H2	≤ 30
	Between distribution box and other distribution boxes	H3	≤ 15
	Between indoor unit and other indoor units	H4	≤ 15
Minimal allowed length	Between outdoor unit and the 1st branch	L1	≥ 5
	Between distribution box and branch pipe	L3; L4; L5	As short as possible

Distribution box should be placed within the level between outdoor unit and indoor unit

DIMENSION OF CONNECTION PIPES

		Gas pipe (mm)	Liquid pipe (mm)
Outdoor unit	MS-E48AIN	∅ 15,9	∅ 9,52
	MS-E56AIN	∅ 19,05	∅ 9,52
Between outdoor unit and the 1st branch	Pipe L1	∅ 19,05	∅ 9,52
Between the 1st and the 2nd branch	Pipe L2	∅ 15,9	∅ 9,52

ADDITIONAL REFRIGERANT CHARGE

$$(x [m] * 0,022 + y [m] * 0,054) - 1,47 = \text{additional refrigerant (Kg)}$$

x - length of liquid pipe ∅ 6 mm

y - length of liquid pipe ∅ 10 mm

APPEARANCE AND DIMENSIONS OF OUTDOOR UNIT

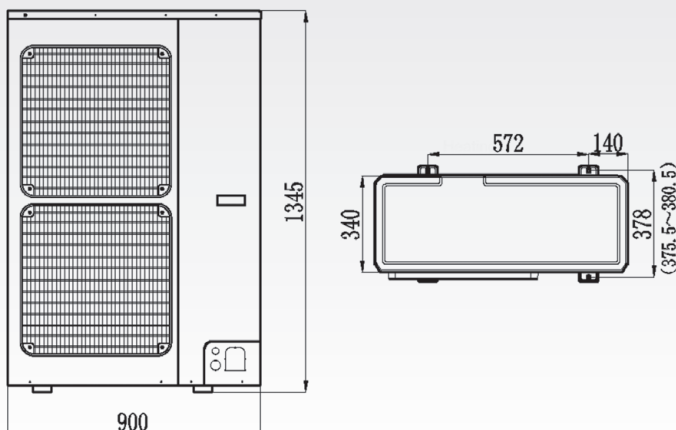

units: mm

APPEARANCE AND DIMENSIONS OF DISTRIBUTION BOXES

HIGH POWER MULTI SYSTEM SERIES

DB2-195B

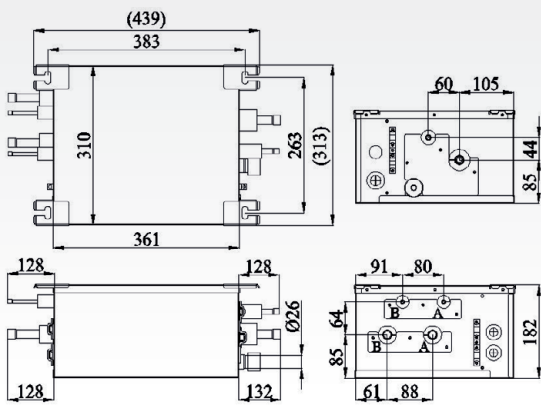

DB3-195B

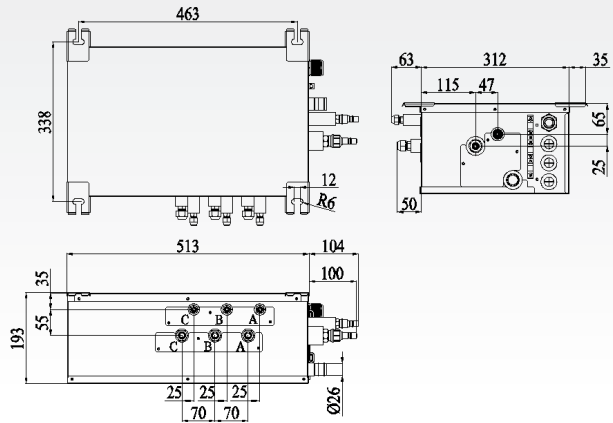

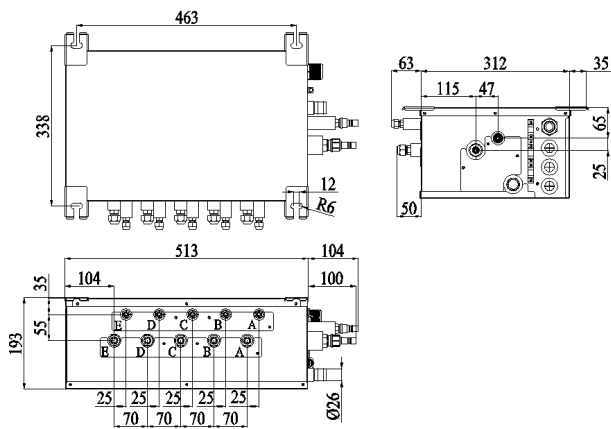

DB5-16AF



units: mm

ELECTRICAL WIRING DIAGRAM

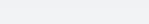
-  Power cable for outdoor unit and distribution boxes (3-core)
-  Refrigerant connection pipe
-  Communication cable (2-core)
-  Power cable for indoor unit (4-core)

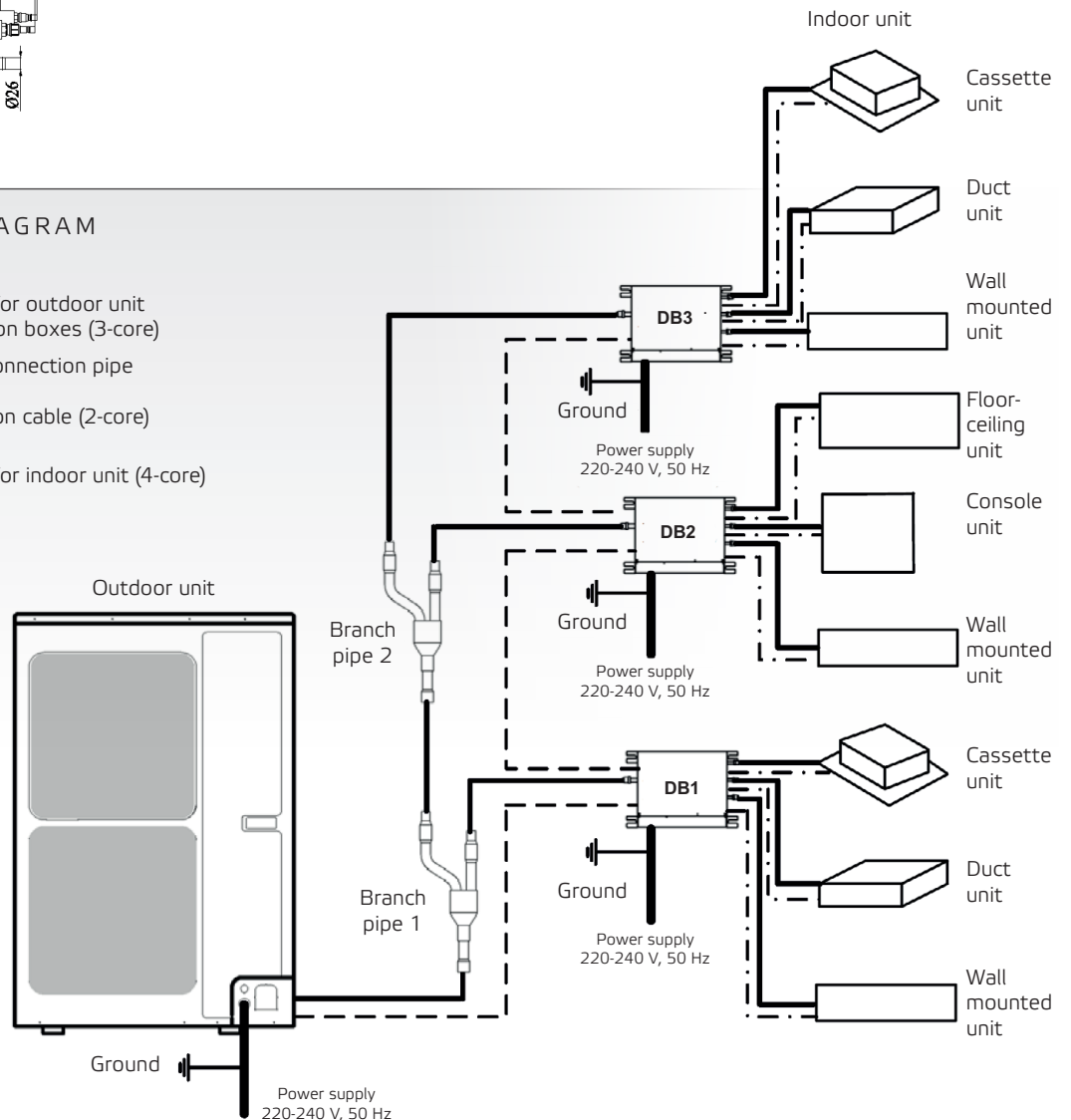

ELECTRICAL WIRING DIAGRAM
HIGH POWER MULTI SYSTEM SERIES

OPTION 1

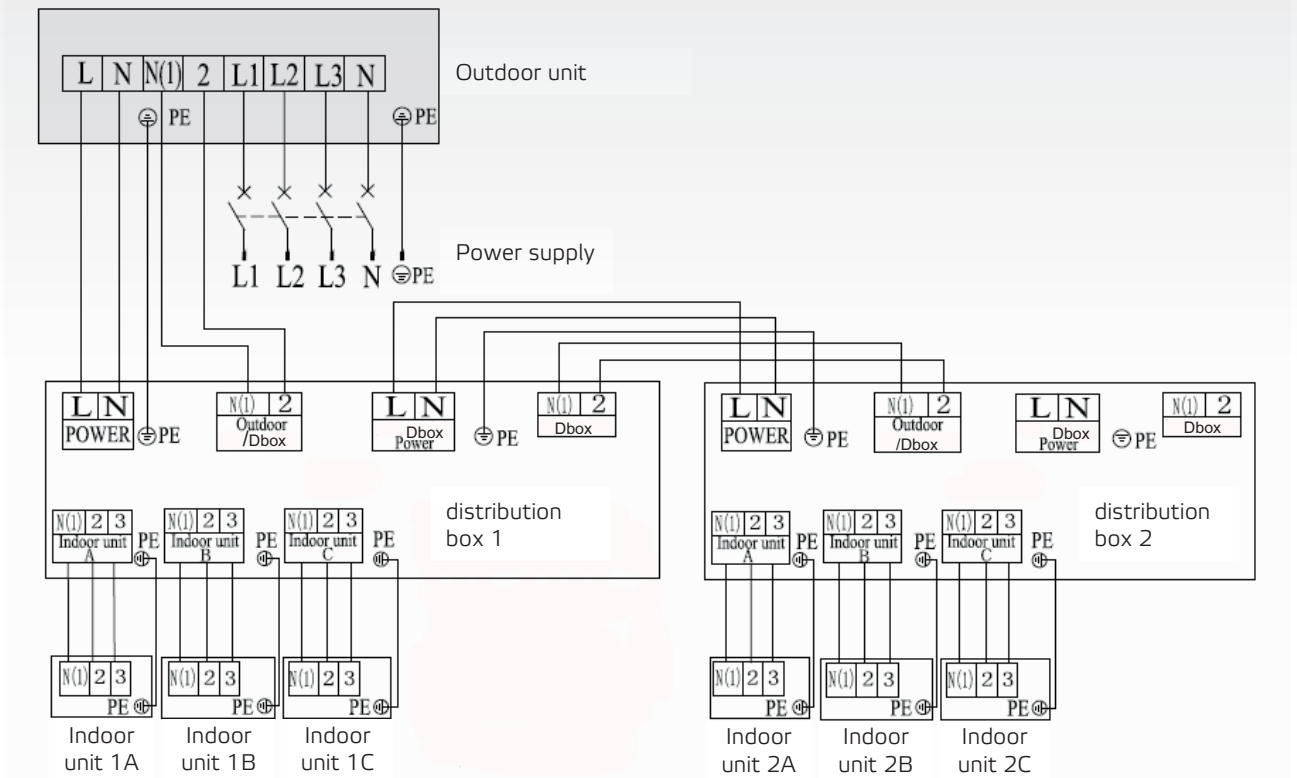

OPTION 2

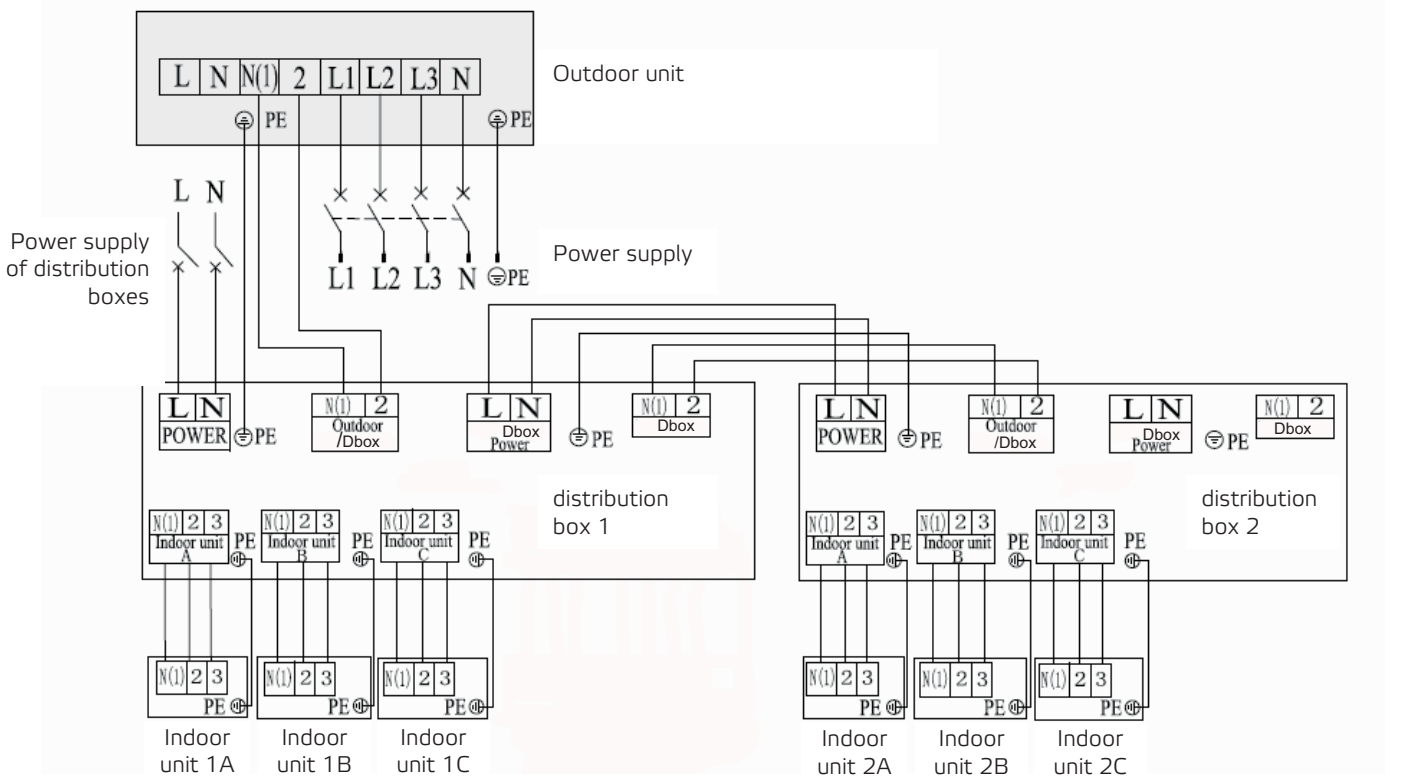

ELECTRICAL WIRING DIAGRAM
HIGH POWER MULTI SYSTEM SERIES

OPTION 3

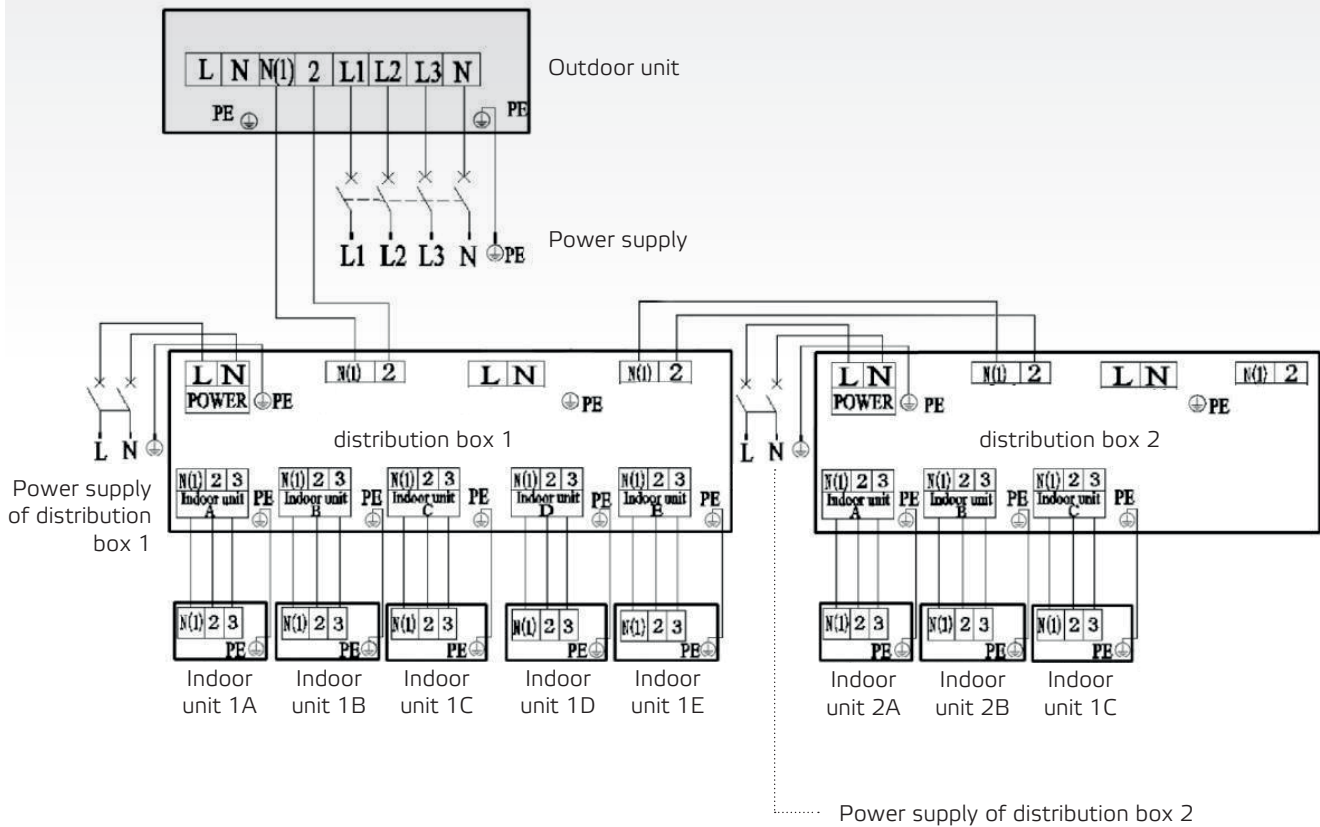

REQUIREMENTS OF POWER CIRCUIT AND CABLE

Frequency		Hz	50
Phase and voltage	Outdoor unit	f, V	3 phases, 380-415
	Distribution box	f, V	1 phase, 220
Recommended cable of outdoor unit (pieces x sectional area)	MS-E48AIN	mm ²	5 x 4,0
	MS-E56AIN	mm ²	5 x 4,0
Recommended cable of distribution box (pieces x sectional area)		mm ²	3 x 1,0
Communication cable (pieces x sectional area)		mm ²	2 x 1,5
Recommended cable of indoor unit (pieces x sectional area)		mm ²	4 x 1,0
Capacity of the air switch	MS-E48AIN	A	20
	MS-E56AIN	A	20
	Distribution box	A	10

OUTDOOR UNITS

HIGH POWER MULTI SYSTEM SERIES

COMBINATION TABLE

(unit: x1000Btu/h)

MS-E48AIN						
2 UNITS						
7+18	9+18	12+12	12+24	18+18	18+24	24+24
7+24	9+24	12+18				
3 UNITS						
7+7+12	7+9+18	7+18+18	9+9+18	9+12+24	12+12+12	12+18+24
7+7+18	7+9+24	7+18+24	9+9+24	9+18+18	12+12+18	12+24+24
7+7+24	7+12+12	7+24+24	9+12+12	9+18+24	12+12+24	18+18+18
7+9+9	7+12+18	9+9+9	9+12+18	9+24+24	12+18+18	18+18+24
7+9+12	7+12+24	9+9+12				
4 UNITS						
7+7+7+7	7+7+9+24	7+9+9+9	7+9+18+18	7+12+18+24	9+9+12+18	9+12+18+18
7+7+7+9	7+7+12+12	7+9+9+12	7+9+18+24	7+18+18+18	9+9+12+24	9+12+18+24
7+7+7+12	7+7+12+18	7+9+9+18	7+9+24+24	9+9+9+9	9+9+18+18	9+18+18+18
7+7+7+18	7+7+12+24	7+9+9+24	7+12+12+12	9+9+9+12	9+9+18+24	12+12+12+12
7+7+7+24	7+7+18+18	7+9+12+12	7+12+12+18	9+9+9+18	9+12+12+12	12+12+12+18
7+7+9+9	7+7+18+24	7+9+12+18	7+12+12+24	9+9+9+24	9+12+12+18	12+12+12+24
7+7+9+12	7+7+24+24	7+9+12+24	7+12+18+18	9+9+12+12	9+12+12+24	12+12+18+18
7+7+9+18						
5 UNITS						
7+7+7+7+7	7+7+7+9+24	7+7+9+9+18	7+7+12+12+24	7+9+9+12+18	7+12+12+12+18	9+9+9+12+24
7+7+7+7+9	7+7+7+12+12	7+7+9+9+24	7+7+12+18+18	7+9+9+12+24	9+9+9+9+9	9+9+9+18+18
7+7+7+7+12	7+7+7+12+18	7+7+9+12+12	7+9+9+9+9	7+9+9+18+18	9+9+9+9+12	9+9+12+12+12
7+7+7+7+18	7+7+7+12+24	7+7+9+12+18	7+9+9+9+12	7+9+12+12+12	9+9+9+9+18	9+9+12+12+18
7+7+7+7+24	7+7+7+18+18	7+7+9+12+24	7+9+9+9+18	7+9+12+12+18	9+9+9+9+24	9+12+12+12+12
7+7+7+9+9	7+7+7+18+24	7+7+9+18+18	7+9+9+9+24	7+9+12+12+24	9+9+9+12+12	9+12+12+12+18
7+7+7+9+12	7+7+9+9+9	7+7+12+12+12	7+9+9+12+12	7+12+12+12+12	9+9+9+12+18	12+12+12+12+12
7+7+7+9+18	7+7+9+9+12	7+7+12+12+18				
6 UNITS						
7+7+7+7+7+7	7+7+7+7+9+12	7+7+7+7+18+18	7+7+7+9+12+18	7+7+9+9+12+12	7+9+9+9+9+18	9+9+9+9+9+9
7+7+7+7+7+9	7+7+7+7+9+18	7+7+7+9+9+9	7+7+7+12+12+12	7+7+9+9+12+18	7+9+9+9+12+12	9+9+9+9+9+12
7+7+7+7+7+12	7+7+7+7+9+24	7+7+7+9+9+12	7+7+7+12+12+18	7+7+9+12+12+12	7+9+9+9+12+18	9+9+9+9+9+18
7+7+7+7+7+18	7+7+7+7+12+12	7+7+7+9+9+18	7+7+9+9+9+9	7+7+12+12+12+12	7+9+9+12+12+12	9+9+9+9+12+12
7+7+7+7+7+24	7+7+7+7+12+18	7+7+7+9+9+24	7+7+9+9+9+12	7+9+9+9+9+9	7+9+12+12+12+12	9+9+9+12+12+12
7+7+7+7+9+9	7+7+7+7+12+24	7+7+7+9+12+12	7+7+9+9+9+18	7+9+9+9+9+12		
7 UNITS						
7+7+7+7+7+7+7	7+7+7+7+7+7+18	7+7+7+7+7+9+18	7+7+7+7+9+9+12	7+7+7+7+12+12+12	7+7+7+9+9+12+12	7+9+9+9+9+9+9
7+7+7+7+7+7+9	7+7+7+7+7+9+9	7+7+7+7+7+12+12	7+7+7+7+9+9+18	7+7+7+9+9+9+9	7+7+9+9+9+9+9	7+9+9+9+9+9+12
7+7+7+7+7+7+12	7+7+7+7+7+9+12	7+7+7+7+9+9+9	7+7+7+7+9+12+12	7+7+9+9+9+9+12	7+7+9+9+9+9+12	9+9+9+9+9+9+9
8 UNITS						
7+7+7+7+7+7+7+7	7+7+7+7+7+7+7+9	7+7+7+7+7+7+7+12	7+7+7+7+7+7+9+9	7+7+7+7+7+7+9+12	7+7+7+7+7+9+9+9	7+7+7+7+7+9+9+9+9
7+9+9+9+9+9+9+9						

When connecting other than recommended combinations, the system will not work.

OUTDOOR UNITS

HIGH POWER MULTI SYSTEM SERIES

COMBINATION TABLE

(unit: x1000Btu/h)

MS-E56AIN						
2 UNITS						
7+18	9+18	12+18	12+24	18+18	18+24	24+24
7+24	9+24					
3 UNITS						
7+7+18	7+12+12	7+24+24	9+12+12	9+18+24	12+12+24	18+18+18
7+7+24	7+12+18	9+9+12	9+12+18	9+24+24	12+18+18	18+18+24
7+9+12	7+12+24	9+9+18	9+12+24	12+12+12	12+18+24	18+24+24
7+9+18	7+18+18	9+9+24	9+18+18	12+12+18	12+24+24	24+24+24
7+9+24	7+18+24					
4 UNITS						
7+7+7+7	7+7+12+12	7+9+9+24	7+12+12+24	9+9+9+24	9+12+12+18	12+12+12+18
7+7+7+9	7+7+12+18	7+9+12+12	7+12+18+18	9+9+12+12	9+12+12+24	12+12+12+24
7+7+7+12	7+7+12+24	7+9+12+18	7+12+18+24	9+9+12+18	9+12+18+18	12+12+18+18
7+7+7+18	7+7+18+18	7+9+12+24	7+18+18+18	9+9+12+24	9+12+18+24	12+12+18+24
7+7+7+24	7+7+18+24	7+9+18+18	7+18+18+24	9+9+18+18	9+12+24+24	12+12+24+24
7+7+9+9	7+7+24+24	7+9+18+24	7+18+24+24	9+9+18+24	9+18+18+18	12+18+18+18
7+7+9+12	7+9+9+9	7+9+24+24	9+9+9+9	9+9+24+24	9+18+18+24	12+18+18+24
7+7+9+18	7+9+9+12	7+12+12+12	9+9+9+12	9+12+12+12	12+12+12+12	18+18+18+18
7+7+9+24	7+9+9+18	7+12+12+18	9+9+9+18			
5 UNITS						
7+7+7+7+7	7+7+7+12+24	7+7+9+18+18	7+9+9+9+18	7+9+12+18+18	9+9+9+9+24	9+9+12+18+24
7+7+7+7+9	7+7+7+18+18	7+7+9+18+24	7+9+9+9+24	7+9+12+18+24	9+9+9+12+12	9+9+18+18+18
7+7+7+7+12	7+7+7+18+24	7+7+9+24+24	7+9+9+12+12	7+9+18+18+18	9+9+9+12+18	9+12+12+12+12
7+7+7+7+18	7+7+7+24+24	7+7+12+12+12	7+9+9+12+18	7+12+12+12+12	9+9+9+12+24	9+12+12+12+18
7+7+7+7+24	7+7+9+9+9	7+7+12+12+18	7+9+9+12+24	7+12+12+12+18	9+9+9+18+18	9+12+12+12+24
7+7+7+9+9	7+7+9+9+12	7+7+12+12+24	7+9+9+18+18	7+12+12+12+24	9+9+9+18+24	9+12+12+18+18
7+7+7+9+12	7+7+9+9+18	7+7+12+18+18	7+9+9+18+24	7+12+12+18+18	9+9+12+12+12	12+12+12+12+12
7+7+7+9+18	7+7+9+9+24	7+7+12+18+24	7+9+12+12+12	9+9+9+9+9	9+9+12+12+18	12+12+12+12+18
7+7+7+9+24	7+7+9+12+12	7+7+18+18+18	7+9+12+12+18	9+9+9+9+12	9+9+12+12+24	12+12+12+12+24
7+7+7+12+12	7+7+9+12+18	7+9+9+9+9	7+9+12+12+24	9+9+9+9+18	9+9+12+18+18	12+12+12+18+18
7+7+7+12+18	7+7+9+12+24	7+9+9+9+12				
6 UNITS						
7+7+7+7+7+7	7+7+7+7+12+18	7+7+7+9+18+18	7+7+9+9+9+24	7+9+9+9+9+9	7+9+9+12+12+18	9+9+9+9+12+18
7+7+7+7+7+9	7+7+7+7+12+24	7+7+7+9+18+24	7+7+9+9+12+12	7+9+9+9+9+12	7+9+12+12+12+12	9+9+9+9+12+24
7+7+7+7+7+12	7+7+7+7+18+18	7+7+7+12+12+12	7+7+9+9+12+18	7+9+9+9+9+18	7+9+12+12+12+18	9+9+9+9+18+18
7+7+7+7+7+18	7+7+7+9+9+9	7+7+7+12+12+18	7+7+9+9+12+24	7+9+9+9+9+24	7+12+12+12+12+12	9+9+9+12+12+12
7+7+7+7+7+24	7+7+7+9+9+12	7+7+7+12+12+24	7+7+9+9+18+18	7+9+9+9+12+12	9+9+9+9+9+9	9+9+9+12+12+18
7+7+7+7+9+9	7+7+7+9+9+18	7+7+7+12+18+18	7+7+9+12+12+12	7+9+9+9+12+18	9+9+9+9+12	9+9+12+12+12+12
7+7+7+7+9+12	7+7+7+9+9+24	7+7+9+9+9+9	7+7+9+12+12+18	7+9+9+9+12+24	9+9+9+9+18	9+9+12+12+12+18
7+7+7+7+9+18	7+7+7+9+12+12	7+7+9+9+9+12	7+7+9+12+12+24	7+9+9+9+18+18	9+9+9+9+24	9+12+12+12+12+12
7+7+7+7+9+24	7+7+7+9+12+18	7+7+9+9+9+18	7+7+9+12+18+18	7+9+9+12+12+12	9+9+9+9+12+12	12+12+12+12+12+12
7+7+7+7+12+12	7+7+7+9+12+24					
7 UNITS						
7+7+7+7+7+7+7	7+7+7+7+7+9+18	7+7+7+7+9+9+12	7+7+7+9+9+9+9	7+7+7+9+12+12+18	7+7+9+9+12+12+12	7+9+9+9+12+12+12
7+7+7+7+7+7+9	7+7+7+7+7+9+24	7+7+7+7+9+9+18	7+7+7+9+9+9+12	7+7+7+12+12+12+12	7+7+9+12+12+12+12	9+9+9+9+9+9+9
7+7+7+7+7+7+12	7+7+7+7+7+12+12	7+7+7+7+9+9+24	7+7+7+9+9+9+18	7+7+9+9+9+9+9	7+9+9+9+9+9+9	9+9+9+9+9+9+12
7+7+7+7+7+7+18	7+7+7+7+7+12+18	7+7+7+7+9+12+12	7+7+7+9+9+9+24	7+7+9+9+9+9+12	7+9+9+9+9+9+12	9+9+9+9+9+9+18
7+7+7+7+7+7+24	7+7+7+7+7+12+24	7+7+7+7+9+12+18	7+7+7+9+9+12+12	7+7+9+9+9+9+18	7+9+9+9+9+9+18	9+9+9+9+9+12+12
7+7+7+7+7+9+9	7+7+7+7+7+18+18	7+7+7+7+12+12+12	7+7+7+9+9+12+18	7+7+9+9+9+12+12	7+9+9+9+9+12+12	9+9+9+9+12+12+12
7+7+7+7+7+9+12	7+7+7+7+9+9+9	7+7+7+7+12+12+18	7+7+7+9+12+12+12	7+7+9+9+9+12+18		
8 UNITS						
7+7+7+7+7+7+7+7	7+7+7+7+7+7+9+9	7+7+7+7+7+7+12+18	7+7+7+7+7+9+12+12	7+7+7+7+9+9+9+12	7+7+7+9+9+9+9+12	7+7+9+9+9+9+9+12
7+7+7+7+7+7+7+9	7+7+7+7+7+7+9+12	7+7+7+7+7+9+9+9	7+7+7+7+7+12+12+12	7+7+7+7+9+9+12+12	7+7+7+9+9+9+12+12	7+9+9+9+9+9+9+9
7+7+7+7+7+7+7+12	7+7+7+7+7+7+9+18	7+7+7+7+7+9+9+12	7+7+7+7+9+9+9+9	7+7+7+9+9+9+9+9	7+7+9+9+9+9+9+9	9+9+9+9+9+9+9+9
7+7+7+7+7+7+7+18	7+7+7+7+7+7+12+12	7+7+7+7+7+9+9+18				
9 UNITS						
7+7+7+7+7+7+7+7+7	7+7+7+7+7+7+7+7+12	7+7+7+7+7+7+7+9+9	7+7+7+7+7+7+7+9+12	7+7+7+7+7+7+9+9+9	7+7+7+7+7+7+9+9+12	7+7+7+7+7+9+9+9+9
7+7+7+7+7+7+7+7+9						

When connecting other than recommended combinations, the system will not work.

4-WAY CASSETTE INDOOR UNITS

UNI SPLIT SERIES

MODEL			ASC-12BI / ASGE-12BI	ASC-18BI / ASGE-18BI	ASC-24BI / ASGE-24BI	ASC-30BI / ASGE-30BI	ASC-36BI / ASGE-36BI
Capacity cooling/heating 1)	Nominal (min-max)	kW	3,5 (0,4-3,7) / 4,0 (0,8-4,1)	5,0 (0,6-5,3) / 5,5 (1,2-5,7)	7,0 (0,8-7,3) / 8,0 (1,6-8,4)	8,5 (1,0-8,9) / 8,8 (2,0-9,1)	10,0 (1,2-10,6) / 12,0 (2,6-12,4)
Power supply		Hz / V	1~ / 50 / 220-240	1~ / 50 / 220-240	1~ / 50 / 220-240	1~ / 50 / 220-240	1~ / 50 / 220-240
Energy class cooling 3)		-	A+	A+	A++	A++	A++
Pdesign cooling		kW	3,5	5,0	7,0	8,5	10,0
SEER		-	5,9	5,9	7,2	6,1	6,1
Annual power consumption		kWh / annum	213	296	340	472	566
Energy class heating 3)	Average climate	-	A+	A+	A	A+	A+
Pdesign heating	Average climate	kW	3,1	4,0	6,4	7,2	9,0
SCOP	Average climate	-	4,0	4,0	3,9	4,0	4,0
Annual power consumption	Average climate	kWh / annum	1069	1405	2297	2616	3139
Airflow of ID	SH/H/M/L	m ³ / h	650 / 580 / 480 / 400	700 / 580 / 480 / 400	1100 / 1050 / 960 / 870	1400 / 1310 / 1180 / 1040	1500 / 1470 / 1380 / 1220
Sound pressure of ID at 1,4m 4)	SH/H/M/L	dB(A)	39 / 36 / 33	44 / 39 / 36 / 33	43 / 42 / 40 / 39	49 / 47 / 44 / 41	50 / 48 / 46 / 42
Sound power of ID 4)	H	dB(A)	57	53	52	58	59
External static pressure	nom/min-max	Pa	-	-	-	-	-
Dehumidifying volume		l / h	-	-	-	-	-
Refrigerant type	Type		R32	R32	R32	R32	R32
Pipe diameter - liquid side 5)	inch / mm		¼ / 6,4	¼ / 6,4	¾ / 9,5	¾ / 9,5	¾ / 9,5
Pipe diameter - gas side 5)	inch / mm		¾ / 9,5	¾ / 12,7	¾ / 15,9	¾ / 15,9	¾ / 15,9
Dimension of ID	w x h x d	mm	570 x 265 x 570	570 x 265 x 570	840 x 240 x 840	840 x 240 x 840	840 x 240 x 840
Dimension of panel	w x h x d	mm	620 x 47,5 x 620	620 x 47,5 x 620	950 x 52 x 950	950 x 52 x 950	950 x 52 x 950
Package dimension of ID	w x h x d	mm	698 x 295 x 653	698 x 295 x 653	963 x 325 x 963	963 x 325 x 963	963 x 325 x 963
Package dimension of panel	w x h x d	mm	701 x 125 x 701	701 x 125 x 701	1033 x 112 x 1038	1033 x 112 x 1038	1033 x 112 x 1038
Weight of ID	net / gross	kg	17 / 22	17 / 22	29 / 36	29 / 36	31 / 38
Weight of panel	net / gross	kg	3,0 / 4,5	3,0 / 4,5	6,0 / 9,5	6,0 / 9,5	6,0 / 9,5
Set temperature range		°C	16-30	16-30	16-30	16-30	16-30
ADDITIONAL TECHNICAL INFORMATION							
Screw holes distance	w x d	mm	520 x 560	520 x 560	660 x 790	660 x 790	660 x 790
Communication cable		mm ²	2 x 0,75	2 x 0,75	2 x 0,75	2 x 0,75	2 x 0,75
Recommended power cable		mm ²	3 x 1,5	3 x 1,5	3 x 1,5	3 x 1,5	3 x 1,5
Recommended air switch		A	6	6	6	6	6
EQUIPMENT							
Plasma generator			-	-	-	-	-
Wifi module					optional (SWM-03)		
Drain pump			✓	✓	✓	✓	✓
Max. lift (from bottom of ID unit)		mm	1000	1000	1000	1000	1000
Dry contact (ON/OFF)			✓	✓	✓	✓	✓
Alarm contact			-	-	-	-	-
Fresh air inlet			✓	✓	✓	✓	✓
Decorative panel			✓	✓	✓	✓	✓
STANDARD ACCESSORIES							
Standard health filter			-	-	-	-	-
Remote controller (IR)			YAP1F6	YAP1F6	YAP1F6	YAP1F6	YAP1F6
Wired controller			XK117	XK117	XK117	XK117	XK117
OPTIONAL ACCESSORIES							
Optional health filters			-	-	-	-	-
Wired controller with weekly timer			SWC-03	SWC-03	SWC-03	SWC-03	SWC-03
Central controller			SCC-16, SCC-36	SCC-16, SCC-36	SCC-16, SCC-36	SCC-16, SCC-36	SCC-16, SCC-36
MODBUS gateway			SMG-01	SMG-01	SMG-01	SMG-01	SMG-01
BACNET gateway			SBG-01	SBG-01	SBG-01	SBG-01	SBG-01
Dry contact gateway			SDG-01	SDG-01	SDG-01	SDG-01	SDG-01

The specification of products is subject to change based on further development of the units by the producer and can be changed without prior notice. Refer to rating label.

R32 (single component refrigerant HFC), GWP of refrigerant used: 675.

Contains fluorinated greenhouse gases covered by the Kyoto Protocol.

Explanatory notes on the very last page of the catalogue.

It is necessary to combine with an appropriate outdoor unit from UNI SPLIT series (ASGE-xxBI, ASGE-xxBI-3).

4-WAY CASSETTE INDOOR UNITS

UNI SPLIT SERIES

MODEL			ASC-36BI / ASGE-36BI-3	ASC-42BI / ASGE-42BI-3	ASC-48BI / ASGE-48BI-3	ASC-60BI / ASGE-60BI-3
Capacity cooling/heating 1)	Nominal (min-max)	kW	10,0 (1,17-10,59) / 12,0 (2,61-12,42)	12,1 (1,5-12,7) / 13,5 (3,1-14,0)	13,4 (1,7-14,1) / 15,5 (3,2-16,0)	16,0 (2,0-15,2) / 17,0 (3,5-17,6)
Power supply		Hz / V	1~ / 50 / 220-240	1~ / 50 / 220-240	1~ / 50 / 220-240	1~ / 50 / 220-240
Energy class cooling 3)		-	A++	A++	A++	A++
Pdesign cooling		kW	10,0	-	-	-
SEER		-	6,1	6,1	6,1	6,1
Annual power consumption		kWh / annum	533	-	-	-
Energy class heating 3)	Average climate	-	A+	A	A+	A
Pdesign heating	Average climate	kW	9,0	-	-	-
SCOP	Average climate	-	4,0	3,8	4,0	3,8
Annual power consumption	Average climate	kWh / annum	3168	-	-	-
Airflow of ID	SH/H/M/L	m ³ / h	1500 / 1470 / 1380 / 1220	1800 / 1690 / 1470 / 1260	1900 / 1690 / 1480 / 1140	2000 / 1880 / 1620 / 1430
Sound pressure of ID at 1,4m 4)	SH/H/M/L	dB(A)	50 / 48 / 46 / 42	51 / 49 / 46 / 42	52 / 51 / 48 / 45	54 / 52 / 50 / 48
Sound power of ID 4)	H	dB(A)	59	60	61	63
External static pressure	nom/min-max	Pa	-	-	-	-
Dehumidifying volume		l / h	-	-	-	-
Refrigerant type	Type		R32	R32	R32	R32
Pipe diameter - liquid side 5)	inch / mm		3/8 / 9,5	3/8 / 9,5	3/8 / 9,5	3/8 / 9,5
Pipe diameter - gas side 5)	inch / mm		1/2 / 15,9	1/2 / 15,9	1/2 / 15,9	1/2 / 15,9
Dimension of ID	w x h x d	mm	840 x 240 x 840	840 x 290 x 840	840 x 290 x 840	840 x 290 x 840
Dimension of panel	w x h x d	mm	950 x 52 x 950	950 x 52 x 950	950 x 52 x 950	950 x 52 x 950
Package dimension of ID	w x h x d	mm	963 x 325 x 963	963 x 379 x 963	963 x 379 x 963	963 x 379 x 963
Package dimension of panel	w x h x d	mm	1033 x 112 x 1038	1033 x 112 x 1038	1033 x 112 x 1038	1033 x 112 x 1038
Weight of ID	net / gross	kg	31 / 38	33 / 41	36 / 44	36 / 44
Weight of panel	net / gross	kg	6,0 / 9,5	6,0 / 9,5	6,0 / 9,5	6,0 / 9,5
Set temperature range		°C	16-30	16-30	16-30	16-30
ADDITIONAL TECHNICAL INFORMATION						
Screw holes distance	w x d	mm	660 x 790	660 x 790	660 x 790	660 x 790
Communication cable		mm ²	2 x 0,75	2 x 0,75	2 x 0,75	2 x 0,75
Recommended power cable		mm ²	3 x 1,5	3 x 1,5	3 x 1,5	3 x 1,5
Recommended air switch		A	6	6	6	6
EQUIPMENT						
Plasma generator			-	-	-	-
Wifi module			optional (SWM-03)			
Drain pump			✓	✓	✓	✓
Max. lift (from bottom of ID unit)		mm	1000	1000	1000	1000
Dry contact (ON/OFF)			✓	✓	✓	✓
Alarm contact			-	-	-	-
Fresh air inlet			✓	✓	✓	✓
Decorative panel			✓	✓	✓	✓
STANDARD ACCESSORIES						
Standard health filter			-	-	-	-
Remote controller (IR)			YAP1F6	YAP1F6	YAP1F6	YAP1F6
Wired controller			XK117	XK117	XK117	XK117
OPTIONAL ACCESSORIES						
Optional health filters			-	-	-	-
Wired controller with weekly timer			SWC-03	SWC-03	SWC-03	SWC-03
Central controller			SCC-16, SCC-36	SCC-16, SCC-36	SCC-16, SCC-36	SCC-16, SCC-36
MODBUS gateway			SMG-01	SMG-01	SMG-01	SMG-01
BACNET gateway			SBG-01	SBG-01	SBG-01	SBG-01
Dry contact gateway			SDG-01	SDG-01	SDG-01	SDG-01

The specification of products is subject to change based on further development of the units by the producer and can be changed without prior notice. Refer to rating label.

R32 (single component refrigerant HFC), GWP of refrigerant used: 675.

Contains fluorinated greenhouse gases covered by the Kyoto Protocol.

Explanatory notes on the very last page of the catalogue.

It is necessary to combine with an appropriate outdoor unit from UNI SPLIT series (ASGE-xxBI, ASGE-xxBI-3).

APPEARANCE AND DIMENSIONS OF CASSETTE INDOOR UNITS

UNI SPLIT SERIES

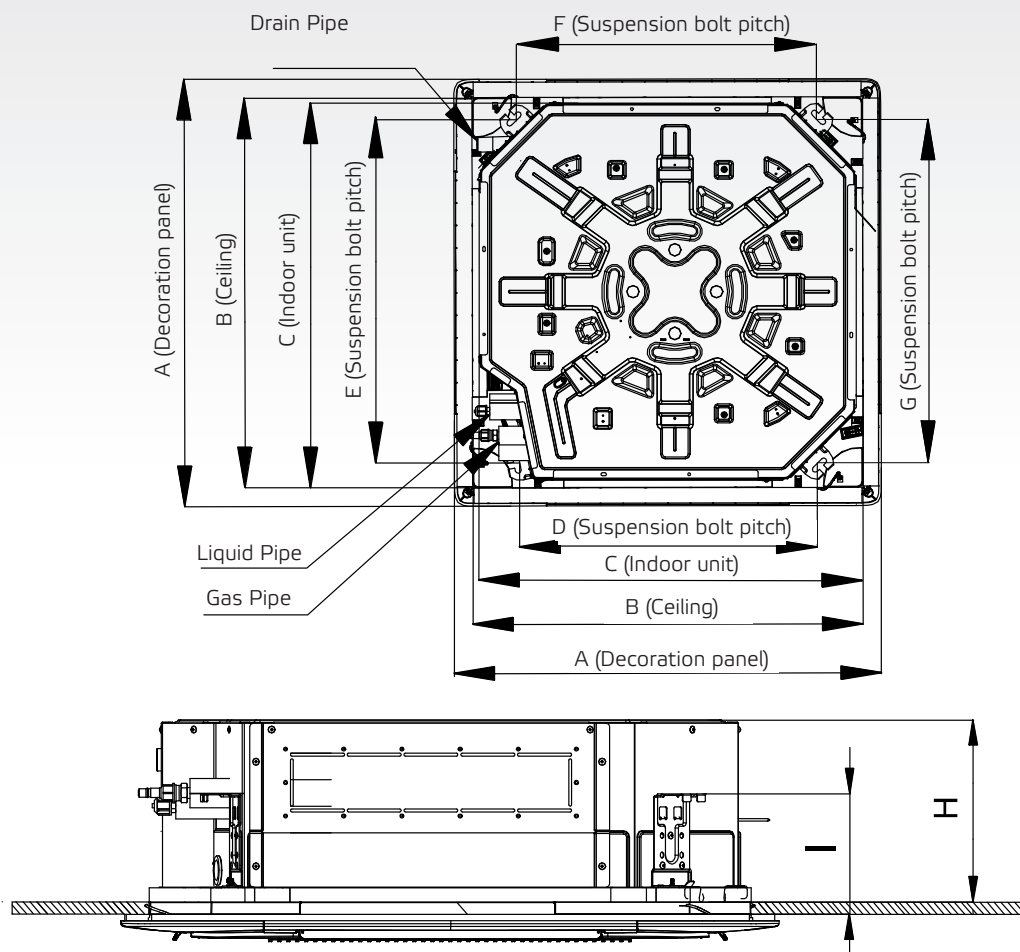

Dimensions	A	B	C	D	E	F	G	H	I
ASC-12BI	620	580	570	500	550	530	530	265	140
ASC-18BI	620	580	570	500	550	530	530	265	140
ASC-24BI	950	870	840	670	770	680	770	240	134
ASC-30BI	950	870	840	670	770	680	770	240	134
ASC-36BI	950	870	840	670	770	680	770	240	134
ASC-42BI	950	870	840	670	770	680	770	290	134
ASC-48BI	950	870	840	670	770	680	770	290	134
ASC-60BI	950	870	840	670	770	680	770	290	134

units: mm

FLOOR-CEILING INDOOR UNITS

UNI SPLIT SERIES

MODEL			ASF-12BI / ASGE-12BI	ASF-18BI / ASGE-18BI	ASF-24BI / ASGE-24BI	ASF-30BI / ASGE-30BI	ASF-36BI / ASGE-36BI
Capacity cooling/heating 1)	Nominal (min-max)	kW	3,5 (0,3-3,7) / 4,0 (0,7-4,1)	5,0 (0,6-5,3) / 5,5 (1,2-5,7)	7,0 (0,7-7,4) / 8,0 (1,8-8,3)	8,5 (1,0-8,9) / 8,8 (2,0-9,1)	10,0 (1,2-10,5) / 12,0 (2,5-12,4)
Power supply		Hz / V	1~ / 50 / 220-240	1~ / 50 / 220-240	1~ / 50 / 220-240	1~ / 50 / 220-240	1~ / 50 / 220-240
Energy class cooling 3)		-	A++	A++	A++	A++	A++
Pdesign cooling		kW	3,5	5,0	7,0	8,5	10,0
SEER		-	6,7	6,1	6,8	6,1	6,1
Annual power consumption		kWh / annum	177	284	359	477	573
Energy class heating 3)	Average climate	-	A+	A+	A	A+	A+
Pdesign heating	Average climate	kW	3,1	4,0	6,4	7,2	9,0
SCOP	Average climate	-	4,0	4,0	3,9	4,0	4,0
Annual power consumption	Average climate	kWh / annum	1040	1394	2295	2577	3149
Airflow of ID	H	m ³ / h	650	850	1300	1500	1600
Sound pressure of ID at 1m 4)	SH/H/M/L	dB(A)	39 / 36 / 32 / 28	44 / 42 / 39 / 36	45 / 44 / 41 / 38	49 / 47 / 45 / 43	49 / 47 / 45 / 43
Sound power of ID 4)	H	dB(A)	51	57	57	65	61
External static pressure	nom/min-max	Pa	-	-	-	-	-
Dehumidifying volume		l / h	-	-	-	-	-
Refrigerant type	Type		R32	R32	R32	R32	R32
Pipe diameter - liquid side 5)	inch / mm		¼ / 6,4	¼ / 6,4	¾ / 9,5	¾ / 9,5	¾ / 9,5
Pipe diameter - gas side 5)	inch / mm		¾ / 9,5	¾ / 12,7	¾ / 15,9	¾ / 15,9	¾ / 15,9
Dimension of ID	w x h x d	mm	870 x 665 x 235	870 x 665 x 235	1200 x 665 x 235	1200 x 665 x 235	1200 x 665 x 235
Dimension of panel	w x h x d	mm	-	-	-	-	-
Package dimension of ID	w x h x d	mm	1033 x 770 x 300	1033 x 770 x 300	1363 x 770 x 300	1363 x 770 x 300	1363 x 770 x 300
Package dimension of panel	w x h x d	mm	-	-	-	-	-
Weight of ID	net / gross	kg	25 / 30	26 / 31	31 / 37	31 / 37	32 / 38
Weight of panel	net / gross	kg	-	-	-	-	-
Set temperature range		°C	16-30	16-30	16-30	16-30	16-30
ADDITIONAL TECHNICAL INFORMATION							
Screw holes distance	w x d	mm	812 x 318	812 x 318	1142 x 318	1142 x 318	1142 x 318
Communication cable		mm ²	2 x 0,75	2 x 0,75	2 x 0,75	2 x 0,75	2 x 0,75
Recommended power cable		mm ²	3 x 1,5	3 x 1,5	3 x 1,5	3 x 1,5	3 x 1,5
Recommended air switch		A	6	6	6	6	6
EQUIPMENT							
Plasma generator			-	-	-	-	-
Wifi module					optional (SWM-03)		
Drain pump			-	-	-	-	-
Max. lift (from bottom of ID unit)		mm	-	-	-	-	-
Dry contact (ON/OFF)			✓	✓	✓	✓	✓
Alarm contact			-	-	-	-	-
Fresh air inlet			-	-	-	-	-
STANDARD ACCESSORIES							
Standard health filter			-	-	-	-	-
Remote controller (IR)			YAP1F6	YAP1F6	YAP1F6	YAP1F6	YAP1F6
Wired controller			XK117	XK117	XK117	XK117	XK117
OPTIONAL ACCESSORIES							
Optional health filters			-	-	-	-	-
Wired controller with weekly timer			SWC-03	SWC-03	SWC-03	SWC-03	SWC-03
Central controller			SCC-16, SCC-36	SCC-16, SCC-36	SCC-16, SCC-36	SCC-16, SCC-36	SCC-16, SCC-36
MODBUS gateway			SMG-01	SMG-01	SMG-01	SMG-01	SMG-01
BACNET gateway			SBG-01	SBG-01	SBG-01	SBG-01	SBG-01
Dry contact gateway			SDG-01	SDG-01	SDG-01	SDG-01	SDG-01

The specification of products is subject to change based on further development of the units by the producer and can be changed without prior notice. Refer to rating label.

R32 (single component refrigerant HFC), GWP of refrigerant used: 675.

Contains fluorinated greenhouse gases covered by the Kyoto Protocol.

Explanatory notes on the very last page of the catalogue.

It is necessary to combine with an appropriate outdoor unit from UNI SPLIT series (ASGE-xxBI, ASGE-xxBI-3).

FLOOR-CEILING INDOOR UNITS

UNI SPLIT SERIES

MODEL			ASF-36BI / ASGE-36BI-3	ASF-42BI / ASGE-42BI-3	ASF-48BI / ASGE-48BI-3	ASF-60BI / ASGE-60BI-3
Capacity cooling/heating 1)	Nominal (min-max)	kW	10,0 (1,2-10,5) / 12,0 (2,5-12,4)	12,1 (1,6-12,7) / 13,5 (3,0-14,0)	13,4 (1,6-14,1) / 15,5 (3,4-16,0)	16,0 (2,0-16,8) / 17,0 (3,7-17,6)
Power supply		Hz / V	1~ / 50 / 220-240	1~ / 50 / 220-240	1~ / 50 / 220-240	1~ / 50 / 220-240
Energy class cooling 3)		-	A++	A++	A++	A++
Pdesign cooling		kW	10,0	-	-	-
SEER		-	6,1	6,1	6,1	6,1
Annual power consumption		kWh / annum	561	-	-	-
Energy class heating 3)	Average climate	-	A+	A	A+	A+
Pdesign heating	Average climate	kW	9,0	-	-	-
SCOP	Average climate	-	4,0	3,8	4,0	4,0
Annual power consumption	Average climate	kWh / annum	3146	-	-	-
Airflow of ID	H	m ³ / h	1600	1800	2100	2300
Sound pressure of ID at 1m 4)	SH/H/M/L	dB(A)	49 / 47 / 45 / 43	49 / 47 / 44 / 42	52 / 50 / 48 / 44	54 / 53 / 49 / 45
Sound power of ID 4)	H	dB(A)	61	61	65	67
External static pressure	nom/min-max	Pa	-	-	-	-
Dehumidifying volume		l / h	-	-	-	-
Refrigerant type	Type		R32	R32	R32	R32
Pipe diameter - liquid side 5)	inch / mm		3/8 / 9,5	3/8 / 9,5	3/8 / 9,5	3/8 / 9,5
Pipe diameter - gas side 5)	inch / mm		1/2 / 15,9	1/2 / 15,9	1/2 / 15,9	1/2 / 15,9
Dimension of ID	w x h x d	mm	1200 x 665 x 235	1570 x 665 x 235	1570 x 665 x 235	1570 x 665 x 235
Dimension of panel	w x h x d	mm	-	-	-	-
Package dimension of ID	w x h x d	mm	1363 x 770 x 300	1729 x 770 x 300	1729 x 770 x 300	1729 x 770 x 300
Package dimension of panel	w x h x d	mm	-	-	-	-
Weight of ID	net / gross	kg	32 / 38	40 / 47	42 / 49	42 / 49
Weight of panel	net / gross	kg	-	-	-	-
Set temperature range		°C	16-30	16-30	16-30	16-30
ADDITIONAL TECHNICAL INFORMATION						
Screw holes distance	w x d	mm	1142 x 318	1512 x 318	1512 x 318	1512 x 318
Communication cable		mm ²	2 x 0,75	2 x 0,75	2 x 0,75	2 x 0,75
Recommended power cable		mm ²	3 x 1,5	3 x 1,5	3 x 1,5	3 x 1,5
Recommended air switch		A	6	6	6	6
EQUIPMENT						
Plasma generator			-	-	-	-
Wifi module			optional (SWM-03)			
Drain pump			-	-	-	-
Max. lift (from bottom of ID unit)		mm	-	-	-	-
Dry contact (ON/OFF)			✓	✓	✓	✓
Alarm contact			-	-	-	-
Fresh air inlet			-	-	-	-
STANDARD ACCESSORIES						
Standard health filter			-	-	-	-
Remote controller (IR)			YAP1F6	YAP1F6	YAP1F6	YAP1F6
Wired controller			XK117	XK117	XK117	XK117
OPTIONAL ACCESSORIES						
Optional health filters			-	-	-	-
Wired controller with weekly timer			SWC-03	SWC-03	SWC-03	SWC-03
Central controller			SCC-16, SCC-36	SCC-16, SCC-36	SCC-16, SCC-36	SCC-16, SCC-36
MODBUS gateway			SMG-01	SMG-01	SMG-01	SMG-01
BACNET gateway			SBG-01	SBG-01	SBG-01	SBG-01
Dry contact gateway			SDG-01	SDG-01	SDG-01	SDG-01

The specification of products is subject to change based on further development of the units by the producer and can be changed without prior notice. Refer to rating label.

R32 (single component refrigerant HFC), GWP of refrigerant used: 675.

Contains fluorinated greenhouse gases covered by the Kyoto Protocol.

Explanatory notes on the very last page of the catalogue.

It is necessary to combine with an appropriate outdoor unit from UNI SPLIT series (ASGE-xxBI, ASGE-xxBI-3).

APPEARANCE AND DIMENSIONS OF FLOOR-CEILING INDOOR UNITS

UNI SPLIT SERIES

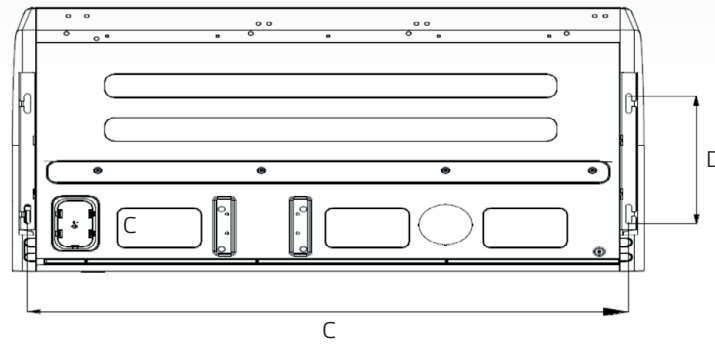
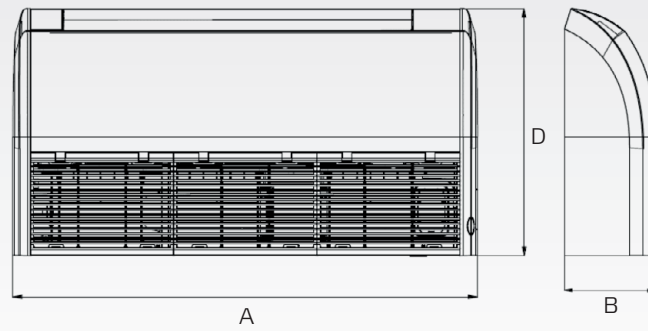

units: mm

	A	B	C	D	H
ASF-12BI	870	235	812	318	665
ASF-18BI	870	235	812	318	665
ASF-24BI	1200	235	1142	318	665
ASF-30BI	1200	235	1142	318	665
ASF-36BI	1200	235	1142	318	665
ASF-42BI	1570	235	1512	318	665
ASF-48BI	1570	235	1512	318	665
ASF-60BI	1570	235	1512	318	665

DUCT INDOOR UNITS

UNI SPLIT SERIES

MODEL			ASD-12BI / ASGE-12BI	ASD-18BI / ASGE-18BI	ASD-24BI / ASGE-24BI	ASD-30BI / ASGE-30BI	ASD-36BI / ASGE-36BI
Capacity cooling/heating 1)	Nominal (min-max)	kW	3,5 (0,7-3,7) / 4,0 (0,8-4,1)	5,0 (0,6-5,3) / 5,5 (1,1-5,7)	7,0 (0,8-7,6) / 8,0 (1,7-8,3)	8,5 (1,0-8,9) / 8,8 (2,0-9,1)	10,0 (1,2-10,6) / 12,0 (2,5-12,4)
Power supply		Hz / V	1~ / 50 / 220-240	1~ / 50 / 220-240	1~ / 50 / 220-240	1~ / 50 / 220-240	1~ / 50 / 220-240
Energy class cooling 3)		-	A++	A++	A++	A++	A++
Pdesign cooling		kW	3,5	5,0	7,0	8,5	10,0
SEER		-	6,1	6,1	6,8	6,1	6,1
Annual power consumption		kWh / annum	200	277	357	480	571
Energy class heating 3)	Average climate	-	A+	A+	A+	A+	A+
Pdesign heating	Average climate	kW	3,1	4,2	6,4	7,2	9,0
SCOP	Average climate	-	4,0	4,0	4,0	4,0	4,0
Annual power consumption	Average climate	kWh / annum	1110	1469	2238	2576	3147
Airflow of ID	H	m ³ / h	650	950	1200	1500	1800
Sound pressure of ID at 1,4m 4)	SH/H/M/L	dB(A)	41 / 38 / 36 / 34	43 / 42 / 39 / 36	40 / 39 / 37 / 36	42 / 40 / 37 / 35	46 / 44 / 42 / 40
Sound power of ID 4)	H	dB(A)	59	58	62	65	65
External static pressure	nom/min-max	Pa	25 (0-50)	25 (0-50)	25 (0-75)	37 (0-75)	37 (0-100)
Dehumidifying volume		l / h	-	-	-	-	-
Refrigerant type	Type		R32	R32	R32	R32	R32
Pipe diameter - liquid side 5)	inch / mm		¼ / 6,4	¼ / 6,4	¾ / 9,5	¾ / 9,5	¾ / 9,5
Pipe diameter - gas side 5)	inch / mm		¾ / 9,5	¾ / 12,7	¾ / 15,9	¾ / 15,9	¾ / 15,9
Dimension of ID	w x h x d	mm	700 x 200 x 450	1000 x 200 x 450	1300 x 220 x 450	1300 x 220 x 450	1000 x 300 x 700
Dimension of panel	w x h x d	mm	-	-	-	-	-
Package dimension of ID	w x h x d	mm	1008 x 275 x 568	1308 x 275 x 568	1570 x 283 x 545	1570 x 283 x 545	1205 x 360 x 813
Package dimension of panel	w x h x d	mm	-	-	-	-	-
Weight of ID	net / gross	kg	20 / 24	26 / 31	31 / 36	31 / 36	41 / 47
Weight of panel	net / gross	kg	-	-	-	-	-
Set temperature range		°C	16-30	16-30	16-30	16-30	16-30
ADDITIONAL TECHNICAL INFORMATION							
Screw holes distance	w x d	mm	760 x 415	1060 x 415	1360 x 415	1360 x 415	1040 x 500
Communication cable		mm ²	2 x 0,75	2 x 0,75	2 x 0,75	2 x 0,75	2 x 0,75
Recommended power cable		mm ²	3 x 1,5	3 x 1,5	3 x 1,5	3 x 1,5	3 x 1,5
Recommended air switch		A	6	6	6	6	6
EQUIPMENT							
Plasma generator			-	-	-	-	-
Wifi module					optional (SWM-03)		
Drain pump			✓	✓	✓	✓	✓
Max. lift (from bottom of ID unit)		mm	1000	1000	1000	1000	1000
Dry contact (ON/OFF)			✓	✓	✓	✓	✓
Alarm contact			-	-	-	-	-
Fresh air inlet			✓	✓	✓	✓	✓
STANDARD ACCESSORIES							
Standard health filter			-	-	-	-	-
Remote controller (IR)			YAP1F6	YAP1F6	YAP1F6	YAP1F6	YAP1F6
Wired controller			XK117	XK117	XK117	XK117	XK117
OPTIONAL ACCESSORIES							
Optional health filters			-	-	-	-	-
Wired controller with weekly timer			SWC-03	SWC-03	SWC-03	SWC-03	SWC-03
Central controller			SCC-16, SCC-36	SCC-16, SCC-36	SCC-16, SCC-36	SCC-16, SCC-36	SCC-16, SCC-36
MODBUS gateway			SMG-01	SMG-01	SMG-01	SMG-01	SMG-01
BACNET gateway			SBG-01	SBG-01	SBG-01	SBG-01	SBG-01
Dry contact gateway			SDG-01	SDG-01	SDG-01	SDG-01	SDG-01

The specification of products is subject to change based on further development of the units by the producer and can be changed without prior notice. Refer to rating label.

R32 (single component refrigerant HFC), GWP of refrigerant used: 675.

Contains fluorinated greenhouse gases covered by the Kyoto Protocol.

Explanatory notes on the very last page of the catalogue.

It is necessary to combine with an appropriate outdoor unit from UNI SPLIT series (ASGE-xxBI, ASGE-xxBI-3).

DUCT INDOOR UNITS

UNI SPLIT SERIES

MODEL			ASD-36BI / ASGE-36BI-3	ASD-42BI / ASGE-42BI-3	ASD-48BI / ASGE-48BI-3	ASD-60BI / ASGE-60BI-3	
Capacity cooling/heating 1)	Nominal (min-max)	kW	10,0 (1,2-10,6) / 12,0 (2,5-12,4)	12,1 (1,6-12,7) / 13,5 (3,0-14,0)	13,4 (1,6-14,1) / 15,5 (3,4-16,0)	16,0 (2,0-16,8) / 17,0 (3,7-17,6)	
Power supply		Hz / V	1~ / 50 / 220-240	1~ / 50 / 220-240	1~ / 50 / 220-240	1~ / 50 / 220-240	
Energy class cooling 3)		-	A++	A+	A+	A++	
Pdesign cooling		kW	10,0	-	-	-	
SEER		-	6,1	5,8	5,4	6,1	
Annual power consumption		kWh / annum	577	-	-	-	
Energy class heating 3)	Average climate	-	A+	A	A	A+	
Pdesign heating	Average climate	kW	9,0	-	-	-	
SCOP	Average climate	-	4,0	3,8	3,7	4,0	
Annual power consumption	Average climate	kWh / annum	3218	-	-	-	
Airflow of ID	H	m ³ / h	1800	2000	2200	2400	
Sound pressure of ID at 1,4m 4)	SH/H/M/L	dB(A)	46 / 44 / 42 / 40	42 / 40 / 39 / 37	43 / 41 / 40 / 38	44 / 41 / 39 / 38	
Sound power of ID 4)	H	dB(A)	65	66	65	66	
External static pressure	nom/min-max	Pa	37 (0-100)	50 (0-150)	50 (0-150)	50 (0-200)	
Dehumidifying volume		l / h	-	-	-	-	
Refrigerant type	Type		R32	R32	R32	R32	
Pipe diameter - liquid side 5)	inch / mm		3/8 / 9,5	3/8 / 9,5	3/8 / 9,5	3/8 / 9,5	
Pipe diameter - gas side 5)	inch / mm		3/8 / 15,9	3/8 / 15,9	3/8 / 15,9	3/8 / 15,9	
Dimension of ID	w x h x d	mm	1000 x 300 x 700	1400 x 300 x 700	1400 x 300 x 700	1400 x 300 x 700	
Dimension of panel	w x h x d	mm	-	-	-	-	
Package dimension of ID	w x h x d	mm	1205 x 360 x 813	1601 x 365 x 813	1601 x 365 x 813	1678 x 365 x 808	
Package dimension of panel	w x h x d	mm	-	-	-	-	
Weight of ID	net / gross	kg	41 / 47	50 / 56	50 / 56	57 / 64	
Weight of panel	net / gross	kg	-	-	-	-	
Set temperature range		°C	16-30	16-30	16-30	16-30	
ADDITIONAL TECHNICAL INFORMATION							
Screw holes distance	w x d	mm	1040 x 500	1440 x 500	1440 x 500	1440 x 500	
Communication cable		mm ²	2 x 0,75	2 x 0,75	2 x 0,75	2 x 0,75	
Recommended power cable		mm ²	3 x 1,5	3 x 1,5	3 x 1,5	3 x 1,5	
Recommended air switch		A	6	6	6	6	
EQUIPMENT							
Plasma generator			-	-	-	-	
Wifi module				optional (SWM-03)			
Drain pump			✓	✓	✓	✓	
Max. lift (from bottom of ID unit)		mm	1000	1000	1000	1000	
Dry contact (ON/OFF)			✓	✓	✓	✓	
Alarm contact			-	-	-	-	
Fresh air inlet			✓	✓	✓	✓	
STANDARD ACCESSORIES							
Standard health filter			-	-	-	-	
Remote controller (IR)			YAP1F6	YAP1F6	YAP1F6	YAP1F6	
Wired controller			XK117	XK117	XK117	XK117	
OPTIONAL ACCESSORIES							
Optional health filters			-	-	-	-	
Wired controller with weekly timer			SWC-03	SWC-03	SWC-03	SWC-03	
Central controller			SCC-16, SCC-36	SCC-16, SCC-36	SCC-16, SCC-36	SCC-16, SCC-36	
MODBUS gateway			SMG-01	SMG-01	SMG-01	SMG-01	
BACNET gateway			SBG-01	SBG-01	SBG-01	SBG-01	
Dry contact gateway			SDG-01	SDG-01	SDG-01	SDG-01	

The specification of products is subject to change based on further development of the units by the producer and can be changed without prior notice. Refer to rating label.

R32 (single component refrigerant HFC), GWP of refrigerant used: 675.

Contains fluorinated greenhouse gases covered by the Kyoto Protocol.

Explanatory notes on the very last page of the catalogue.

It is necessary to combine with an appropriate outdoor unit from UNI SPLIT series (ASGE-xxBI, ASGE-xxBI-3).

APPEARANCE AND DIMENSIONS OF DUCT INDOOR UNITS

UNI SPLIT SERIES

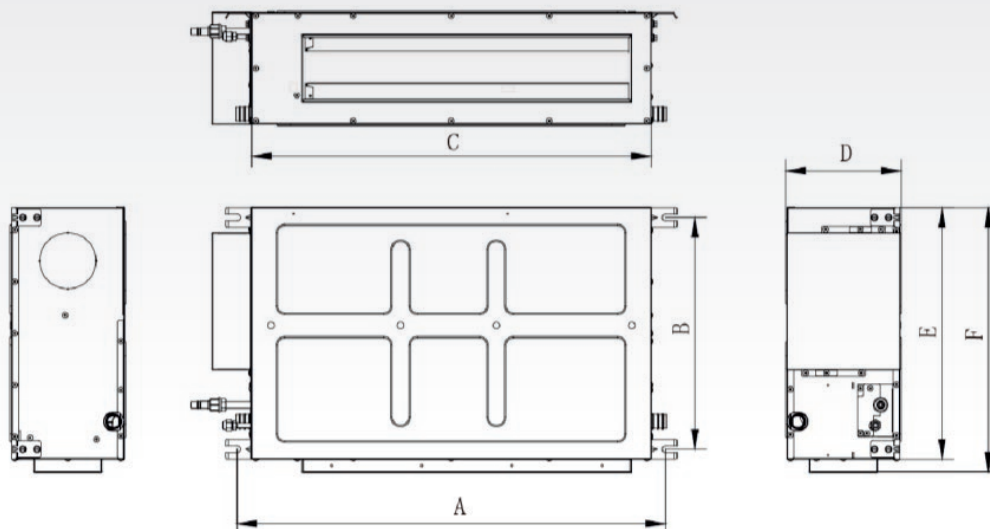

Dimensions Model	A	B	C	D	E	F
ASD-12BI	760	415	700	200	450	474
ASD-18BI	1060	415	1000	200	450	474
ASD-24BI	1360	415	1300	220	450	474
ASD-30BI						
ASD-36BI	1040	500	1000	300	700	754
ASD-42BI	1440	500	1400	300	700	754
ASD-48BI						
ASD-60BI						

DIMENSIONS OF AIR INLET AND OUTLET

UNI SPLIT SERIES

Air outlet

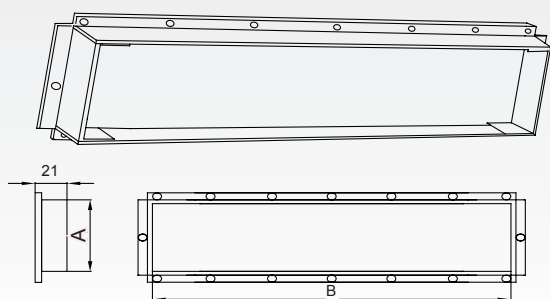

Air inlet

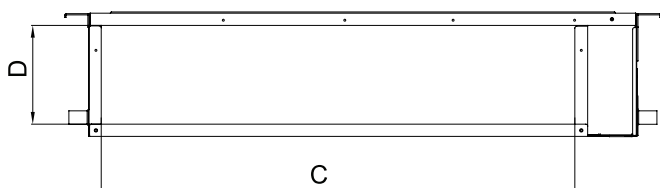

Dimensions	Air outlet		Air inlet	
	A	B	C	D
ASD-12BI	122	585	700	200
ASD-18BI	122	885	1000	200
ASD-24BI	142	1185	1300	220
ASD-30BI				
ASD-36BI	195	746	960	264
ASD-42BI	195	1150	1360	264
ASD-48BI				
ASD-60BI				

WALL MOUNTED INDOOR UNITS

UNI SPLIT SERIES

MODEL			ASH-24BIH	ASH-36BIH			
Capacity cooling/heating 1)	Nominal (min-max)	kW	7,0 (0,7-7,4) / 8,0 (1,8-8,3)	10,0 (1,2-10,5) / 12,0 (2,5-12,4)			
Power supply		Hz / V	1~ / 50 / 220-240	1~ / 50 / 220-240			
Energy class cooling 3)			A++	A++			
Pdesign cooling		kW	7,0	10,0			
SEER			6,8	6,1			
Annual power consumption		kWh / annum	359	573			
Energy class heating 3)	Average climate		A	A+			
Pdesign heating	Average climate	kW	6,4	9,0			
SCOP	Average climate		4,0	4,0			
Annual power consumption	Average climate	kWh / annum	2295	3149			
Airflow of ID	H	m ³ / h	1300	1600			
Sound pressure of ID at 1m 4)	H/M/L	dB(A)	45 / 43 / 40	52 / 46 / 43			
Sound power of ID 4)	H	dB(A)	51	57			
External static pressure	nom/min-max	Pa	-	-			
Dehumidifying volume		l / h	2,3	3,8			
Refrigerant type		Type	R32	R32			
Pipe diameter - liquid side 5)		inch / mm	¾ / 9,5	¾ / 9,5			
Pipe diameter - gas side 5)		inch / mm	¾ / 15,9	¾ / 15,9			
Dimension of ID	w x h x d	mm	1078 x 325 x 246	1350 x 326 x 253			
Dimension of panel	w x h x d	mm	-	-			
Package dimension of ID	w x h x d	mm	1127 x 403 x 344	1441 x 421 x 367			
Package dimension of panel	w x h x d	mm	-	-			
Weight of ID	net / gross	kg	15 / 18	18 / 23			
Weight of panel	net / gross	kg	-	-			
Set temperature range		°C	16-30	16-30			
ADDITIONAL TECHNICAL INFORMATION							
Screw holes distance of OD	w x d	mm	560 x 364	560 x 364			
Communication cable		mm ²	2 x 0,75				
Recommended power cable		mm ²	3 x 1,5	3 x 1,5			
Recommended air switch		A	6	6			
EQUIPMENT							
Plasma generator	indoor		✓	✓			
Wifi module			✓	✓			
Drain pump			-	-			
Max. lift (from bottom of ID unit)		mm		-	-		
Dry contact (ON/OFF)				✓	✓		
Alarm contact				-	-		
Fresh air inlet				-	-		
STANDARD ACCESSORIES							
Standard health filter			-	-			
Remote controller (IR)			YAN1F6 (wifi)	YAN1F6 (wifi)			
Wired controller			-	-			
OPTIONAL ACCESSORIES							
Optional health filters			SAF-OPWB4, SAF-OPWK4, SAF-OPWM4, SAF-OPWP4, SAF-OPWS4	-			
Wired controller			XK117,SWC-03	XK117,SWC-03			
Central controller			SCC-16, SCC-36	SCC-16, SCC-36			
MODBUS gateway			SMG-01	SMG-01			
BACNET gateway			SBG-01	SBG-01			
Dry contact gateway			SDG-01	SDG-01			

The specification of products is subject to change based on further development of the units by the producer and can be changed without prior notice. Refer to rating label.
R32 (single component refrigerant HFC), GWP of refrigerant used: 675.
Contains fluorinated greenhouse gases covered by the Kyoto Protocol.
Explanatory notes on the very last page of the catalogue.
The device is being sold as a set (indoor + outdoor unit)

APPEARANCE AND DIMENSIONS OF INDOOR UNIT

UNI SPLIT SERIES

ASH-24BIH

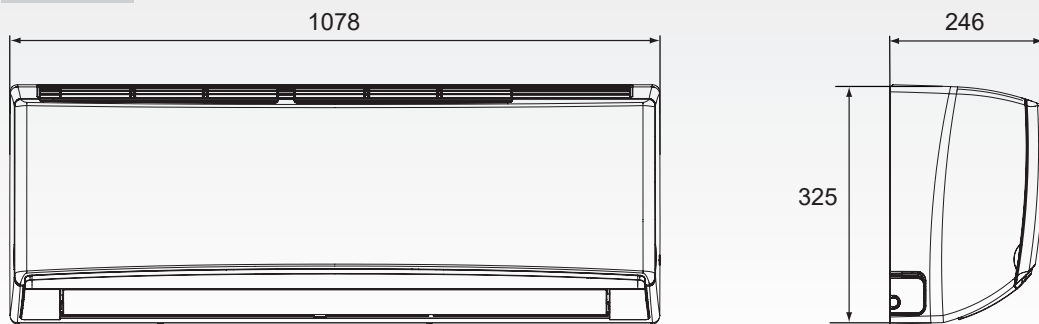

ASH-36BIH

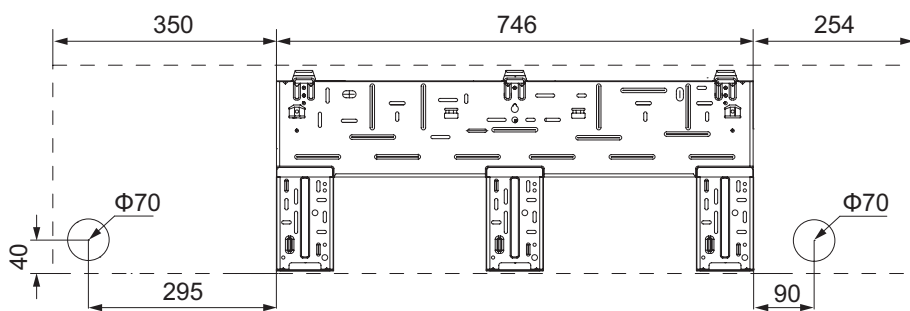
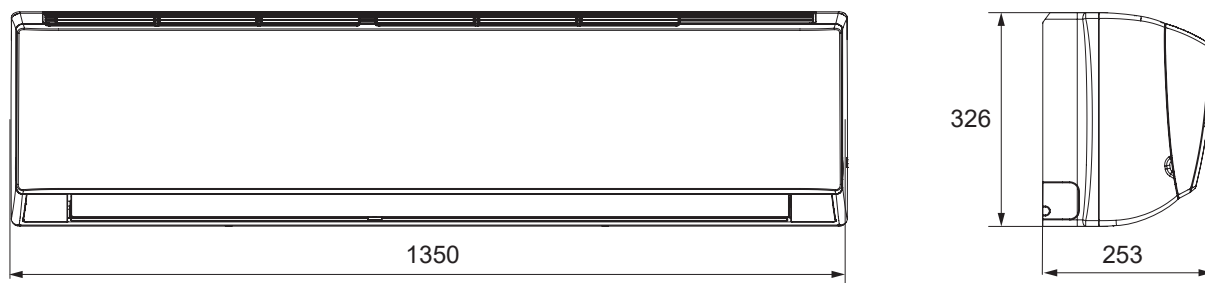

OUTDOOR UNITS

UNI SPLIT SERIES

MODEL			ASGE-12BI	ASGE-18BI	ASGE-24BI	ASGE-30BI	ASGE-36BI
Capacity cooling/heating 1)	Nominal	kW	3,5 / 4,0	5,0 / 5,5	7,0 / 8,0	8,5 / 8,8	10,0 / 12,0
Power supply		Hz / V	1~ / 50 / 220-240	1~ / 50 / 220-240	1~ / 50 / 220-240	1~ / 50 / 220-240	1~ / 50 / 220-240
Power input cooling/heating 1)		W	950 / 1050	1550 / 1450	2100 / 2450	2800 / 2650	3300 / 3600
Maximal power input 2)		W	1350	1750	3500	3950	4050
Power current cooling/heating		A	4,18 / 4,70	6,50 / 6,90	8,80 / 10,50	12,7 / 11,7	14,5 / 15,9
Maximal power current 2)		A	6,0	8,0	16,0	18,0	18,5
Airflow of ID	H	m ³ / h	3000	3000	3600	4000	5900
Sound pressure of ID at 1m 4)	H	dB(A)	50	50	52	53	55
Sound power of ID 4)	H	dB(A)	64	65	67	69	70
Refrigerant type/charge		Type / kg / t eq. CO ₂	R32 / 0,78 / 0,53	R32 / 1,00 / 0,68	R32 / 1,60 / 1,08	R32 / 1,80 / 1,22	R32 / 2,50 / 1,69
Additional refrigerant		g / m	16	16	40	40	40
Pipe diameter - liquid side 5)		inch / mm	¼ / 6,4	¼ / 6,4	¾ / 9,5	¾ / 9,5	¾ / 9,5
Pipe diameter - gas side 5)		inch / mm	¾ / 9,5	¾ / 12,7	¾ / 15,9	¾ / 15,9	¾ / 15,9
Max pipe length without additional refrigerant 6)		m	5	5	5	5	5
Allowed pipe length 7)	min/max	m	3 / 30	3 / 35	3 / 50	3 / 50	3 / 65
Max. elevation/ Drop height		m	15	20	25	25	30
Dimension of ID	w x h x d	mm	818 x 596 x 378	818 x 596 x 378	892 x 698 x 396	920 x 790 x 427	940 x 820 x 530
Package dimension of ID	w x h x d	mm	948 x 645 x 420	948 x 645 x 420	1029 x 750 x 458	1083 x 855 x 488	1073 x 868 x 563
Weight of ID	net / gross	kg	37 / 40	39 / 42	53 / 57	60 / 65	83 / 95
Operating temperature range cooling 8)		°C	-20~48	-20~48	-20~48	-20~48	-20~48
Operating temperature range heating 8)		°C	-20~24	-20~24	-20~24	-20~24	-20~24
ADDITIONAL TECHNICAL INFORMATION							
Screw holes distance of OD	w x d	mm	550 x 348	550 x 348	560 x 364	610 x 395	610 x 486
Communication cable		mm ²	2 x 0,75	2 x 0,75	2 x 0,75	2 x 0,75	2 x 0,75
Recommended power cable		mm ²	3 x 1,5	3 x 2,5	3 x 2,5	3 x 4,0	3 x 4,0
Recommended air switch		A	13	16	16	20	20
EQUIPMENT							
Throttling method			EXV	EXV	EXV	EXV	EXV
Bottom chassis heater			-	-	-	-	-
Crankcase heater			Preheating	Preheating	Preheating	Preheating	Heating belt
Bottom plugs for OD			✓	✓	✓	✓	✓
Drain pipe connector			✓	✓	✓	✓	✓
OPTIONAL ACCESSORIES							
Communication module			SCMI-01.4	SCMI-01.4	SCMI-01.4	SCMI-01.4	SCMI-01.4

The specification of products is subject to change based on further development of the units by the producer and can be changed without prior notice. Refer to rating label.

R32 (single component refrigerant HFC), GWP of refrigerant used: 675.

Contains fluorinated greenhouse gases covered by the Kyoto Protocol.

Explanatory notes on the very last page of the catalogue.

It is necessary to combine with an appropriate indoor unit from UNI SPLIT series (ASC-xxBI, ASD-xxBI, ASF-xxBI, ASH-xxBIH).

OUTDOOR UNITS

UNI SPLIT SERIES

MODEL			ASGE-36BI-3	ASGE-42BI-3	ASGE-48BI-3	ASGE-60BI-3
Capacity cooling/heating 1)	Nominal	kW	10,0 / 12,0	12,1 / 13,5	13,4 / 15,5	16,0 / 17,0
Power supply		Hz / V	3~ / 50 / 380-415	3~ / 50 / 380-415	3~ / 50 / 380-415	3~ / 50 / 380-415
Power input cooling/heating 1)		W	3300 / 3500	4050 / 4150	4700 / 4450	5450 / 5400
Maximal power input 2)		W	4650	5300	5950	5950
Power current cooling/heating		A	5,1 / 5,6	5,9 / 6,1	7,2 / 6,7	7,7 / 7,6
Maximal power current 2)		A	7	8	9	9
Airflow of ID	H	m ³ / h	5900	5900	5900	6600
Sound pressure of ID at 1m 4)	H	dB(A)	55	56	57	57
Sound power of ID 4)	H	dB(A)	70	71	72	72
Refrigerant type/charge		Type / kg / t eq. CO ₂	R32 / 2,5 / 1,69	R32 / 2,65 / 1,79	R32 / 2,8 / 1,89	R32 / 3,6 / 2,43
Additional refrigerant		g / m	40	40	40	40
Pipe diameter - liquid side 5)		inch / mm	¾ / 9,5	¾ / 9,5	¾ / 9,5	¾ / 9,5
Pipe diameter - gas side 5)		inch / mm	¾ / 15,9	¾ / 15,9	¾ / 15,9	¾ / 15,9
Max pipe length without additional refrigerant 6)		m	5	5	7,5	7,5
Allowed pipe length 7)	min/max	m	3 / 65	3 / 75	3 / 75	3 / 75
Max. elevation/ Drop height		m	30	30	30	30
Dimension of ID	w x h x d	mm	940 x 820 x 530	940 x 820 x 530	940 x 820 x 530	900 x 1345 x 412
Package dimension of ID	w x h x d	mm	1073 x 868 x 563	1073 x 868 x 563	1073 x 868 x 563	1033 x 1395 x 443
Weight of ID	net / gross	kg	89 / 101	95 / 107	99 / 111	112 / 122
Operating temperature range cooling 8)		°C	-20~48	-20~48	-20~48	-20~48
Operating temperature range heating 8)		°C	-20~24	-20~24	-20~24	-20~24
ADDITIONAL TECHNICAL INFORMATION						
Screw holes distance of OD	w x d	mm	610 x 486	610 x 486	610 x 486	572 x 378
Communication cable		mm ²	2 x 0,75	2 x 0,75	2 x 0,75	2 x 0,75
Recommended power cable		mm ²	5 x 2,5	5 x 2,5	5 x 2,5	5 x 2,5
Recommended air switch		A	16	16	16	16
EQUIPMENT						
Throttling method			EXV	EXV	EXV	EXV
Bottom chassis heater			-	-	-	-
Crankcase heater			Heating belt	Heating belt	Heating belt	Heating belt
Bottom plugs for OD			✓	✓	✓	✓
Drain pipe connector			✓	✓	✓	✓
OPTIONAL ACCESSORIES						
Communication module			SCMI-01.4	SCMI-01.4	SCMI-01.4	SCMI-01.4

The specification of products is subject to change based on further development of the units by the producer and can be changed without prior notice. Refer to rating label.

R32 (single component refrigerant HFC), GWP of refrigerant used: 675.

Contains fluorinated greenhouse gases covered by the Kyoto Protocol.

Explanatory notes on the very last page of the catalogue.

It is necessary to combine with an appropriate indoor unit from UNI SPLIT series (ASC-xxBI, ASD-xxBI, ASF-xxBI).

APPEARANCE AND DIMENSIONS OF OUTDOOR UNIT

UNI SPLIT SERIES

ASGE-12BI, ASGE-18BI, ASGE-24BI, ASGE-30BI

ASGE-36BI, ASGE-36BI-3, ASGE-42BI-3, ASGE-48BI-3

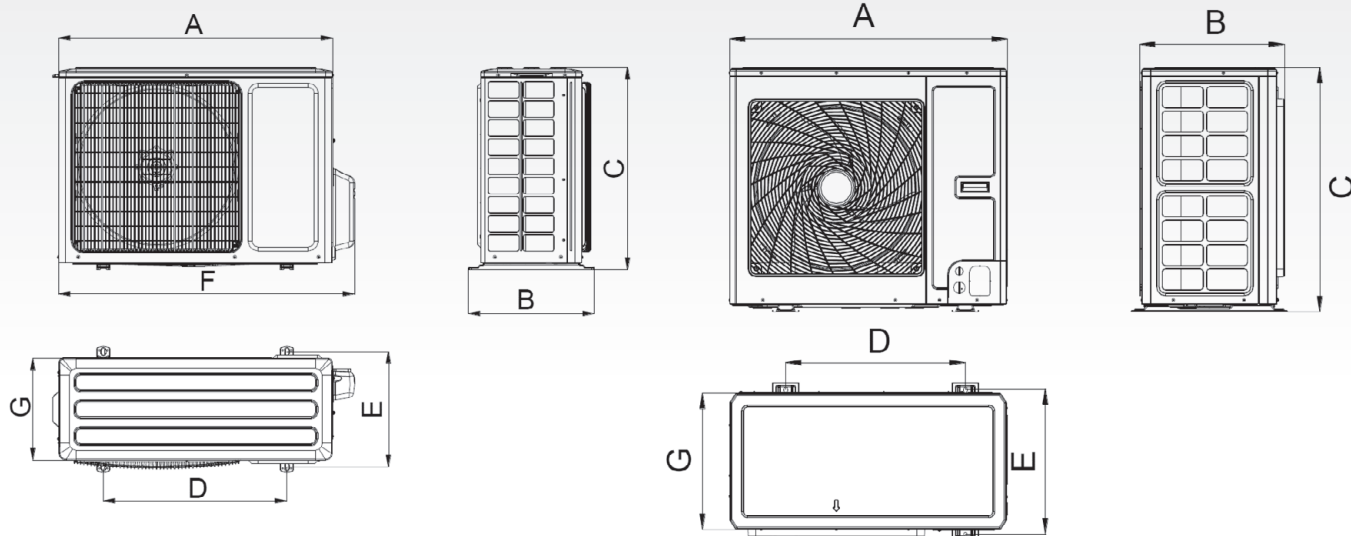

ASGE-60BI-3

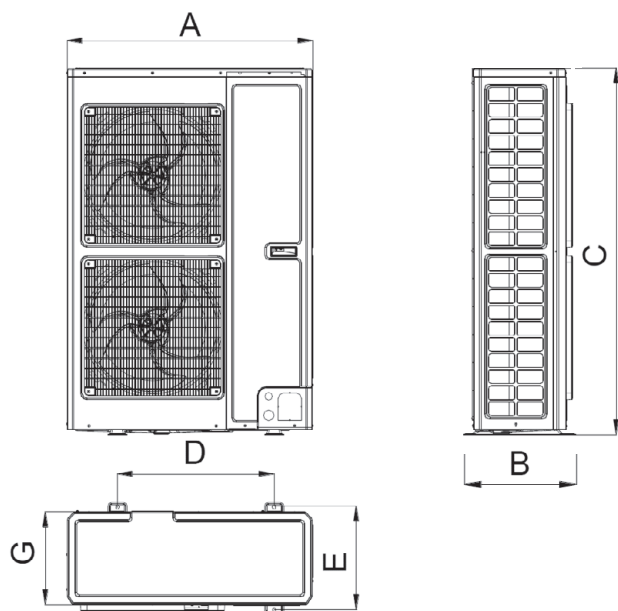

Dimensions Model	A	B	C	D	E	F	G
ASGE-12BI	818	378	596	550	348	887	302
ASGE-18BI	818	378	596	550	348	887	302
ASGE-24BI	892	396	698	560	364	952	340
ASGE-30BI	920	427	790	610	395	1002	370
ASGE-36BI	940	530	820	610	486	/	460
ASGE-36BI-3	940	530	820	610	486	/	460
ASGE-42BI-3	940	530	820	610	486	/	460
ASGE-48BI-3	940	530	820	610	486	/	460
ASGE-60BI-3	900	412	1345	572	378	/	340

units: mm

ELECTRICAL WIRING DIAGRAM

UNI SPLIT SERIES

ASGE-12BI, ASGE-18BI, ASGE-24BI, ASGE-30BI

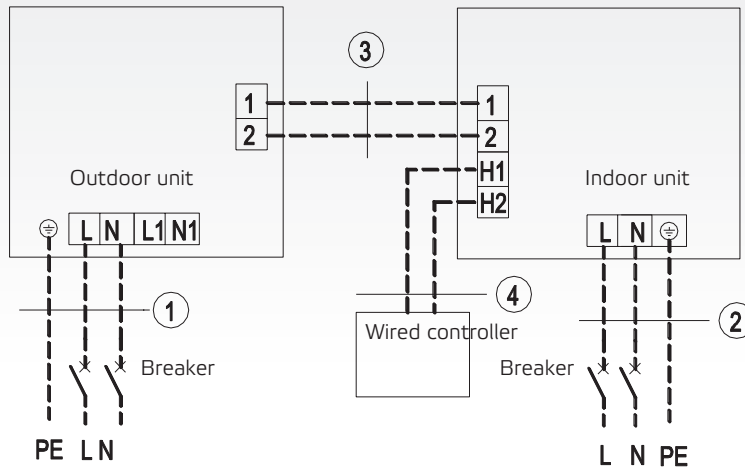

Power : 220–240 V~, 50 Hz / 208–230 V~, 60 Hz

Power : 220–240 V~, 50 Hz / 208–230 V~, 60 Hz

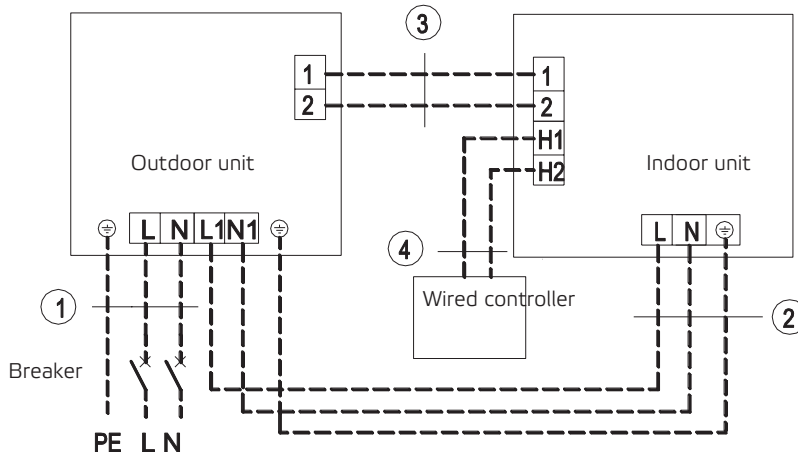

Power : 220–240 V~, 50 Hz / 208–230 V~, 60 Hz

Power : 220–240 V~, 50 Hz / 208–230 V~, 60 Hz

1 Outdoor unit power supply **2** Indoor unit power supply **3** Communication cable **4** Communication cable

ELECTRICAL WIRING DIAGRAM

UNI SPLIT SERIES

ASGE-36BI

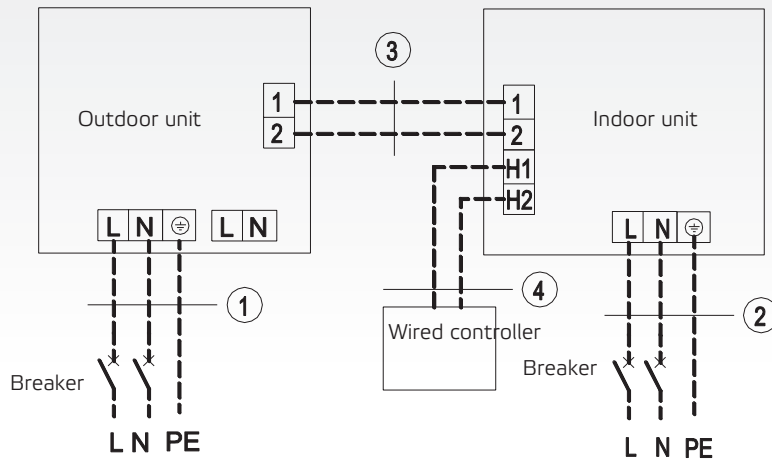

Power : 220–240 V~, 50 Hz / 208–230 V~, 60 Hz

Power : 220–240 V~, 50 Hz / 208–230 V~, 60 Hz

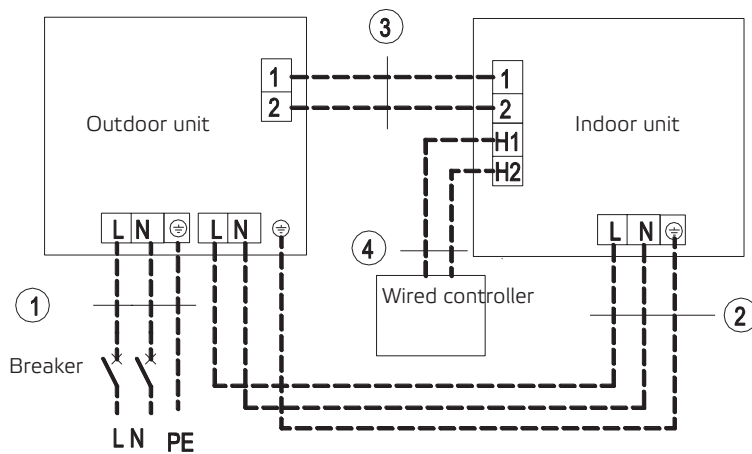

Power : 220–240 V~, 50 Hz / 208–230 V~, 60 Hz

Power : 220–240 V~, 50 Hz / 208–230 V~, 60 Hz

1 Outdoor unit power supply **2** Indoor unit power supply **3** Communication cable **4** Communication cable

ELECTRICAL WIRING DIAGRAM

UNI SPLIT SERIES

ASGE-36BI-3, ASGE-42BI-3, ASGE-48BI-3, ASGE-60BI-3

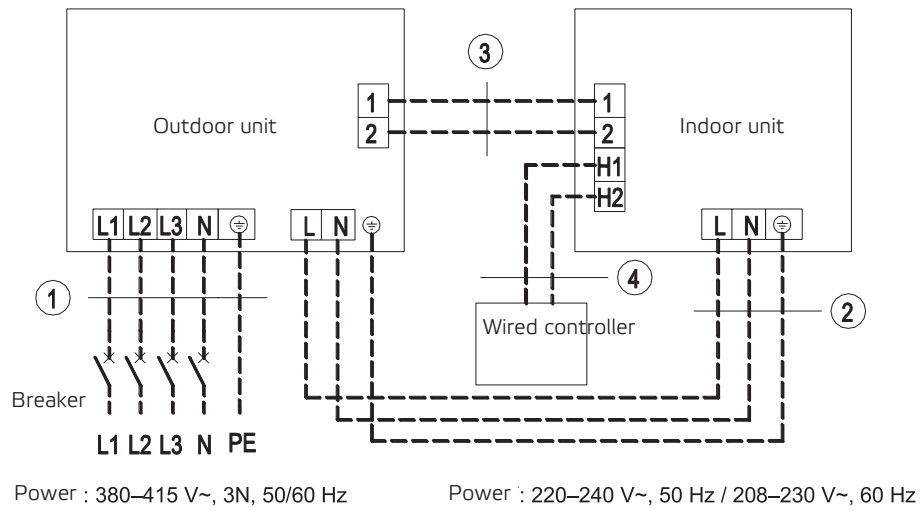
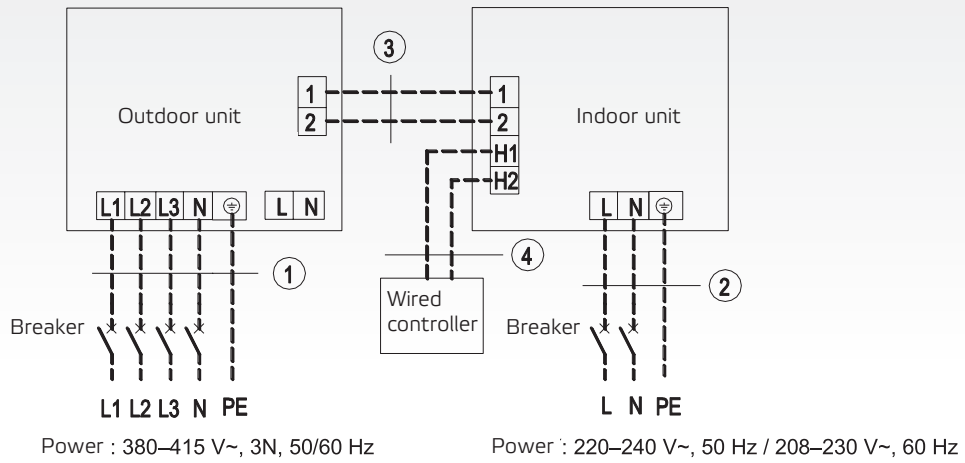

1 Outdoor unit power supply 2 Indoor unit power supply 3 Communication cable 4 Communication cable

SPLIT AIR CONDITIONER

HIGH STATIC PRESSURE DUCT UNIT

MODEL		ASDH-96AI				
Capacity cooling/heating 1)	Nominal	kW	28,0 / 31,5			
Power supply ID		Hz / V	1~ / 50 / 220-240			
Power supply OD		-	3~ / 50 / 380-415			
Power input cooling/heating 1)		W	9000 / 8500			
Maximal power input 2)		W	11700			
Nominal current cooling/heating of ID		A	4,5			
Nominal power current of OD 2)		A	16,0			
EER / COP		-	3,11 / 3,71			
Airflow of ID	H/M/L	m³ / h	4800 / 4100 / 3000			
Airflow of OD	H	m³ / h	9800			
Sound pressure of ID 4)	min-max	dB(A)	49-52			
Sound pressure of OD 4)	H	dB(A)	59			
Sound power of ID 4)	H/M/L	dB(A)	-			
Sound power of OD 4)	V	dB(A)	77			
External static pressure		Pa	0~150			
Dehumidifying volume		l / h	-			
Refrigerant type/charge		Type / kg / t eq. CO ₂	R410A / 7,2 / 15,03			
Additional refrigerant		g / m	30			
Pipe diameter - liquid side 5)		inch / mm	¾ / 9,5			
Pipe diameter - gas side 5)		inch / mm	1 / 25,4			
Max pipe length without additional refrigerant 6)		m	5			
Maximal allowed pipe length 7)		m	50			
Max. elevation / Drop height*		m	25 / 30			
Dimension of ID	w x h x d	mm	1470 x 512 x 775			
Dimensions of OD	w x h x d	mm	1120 x 1558 x 528			
Package dimension of ID	w x h x d	mm	1555 x 545 x 875			
Package dimensions of OD	w x h x d	mm	1270 x 1720 x 565			
Weight of ID	net / gross	kg	83 / 92			
Weight of OD	net / gross	kg	148 / 164			
Set temperature range		°C	17~30			
Operating temperature range 8)	cooling	°C	-15~48			
	heating	°C	-15~24			
ADDITIONAL TECHNICAL INFORMATION						
Screw holes distance of OD	w (w2) x d	mm	668 (874) x 494			
Communication cable		mm²	3 x 0,75			
Recommended power cable	indoor	mm²	3 x 2,5			
	outdoor	mm²	5 x 6			
Recommended air switch	indoor	A	16			
	outdoor	A	40			
EQUIPMENT						
Plasma generator	indoor		-			
Wifi module			-			
Drain pump			-			
Max. lift (from bottom of ID unit)		mm	-			
Dry contact (ON/OFF)			✓			
Alarm contact			✓			
Fresh air inlet	outdoor		-			
Throttling method			EXV			
Bottom chassis heater			-			
Crankcase heater			✓			
Bottom plugs for OD			✓			
Drain pipe connector			✓			
STANDARD ACCESSORIES						
Standard health filter			-			
Remote controller (IR)			-			
Wired controller			KJR-29B1 / BK-E			
OPTIONAL ACCESSORIES						
Optional health filters			-			
Wired controller			-			
Central controller			CCM30, CCM09			

* Outdoor unit above indoor unit / Outdoor unit below indoor unit

The specification of products is subject to change based on further development of the units by the producer and can be changed without prior notice. Refer to rating label.

R410A (50% HFC-32, 50% HFC-125), GWP 2088

Contains fluorinated greenhouse gases covered by the Kyoto Protocol.

Explanatory notes on the very last page of the catalogue.

The device is being sold as a set (indoor + outdoor unit).

APPEARANCE AND DIMENSIONS OF UNITS
HIGH STATIC PRESSURE DUCT UNIT

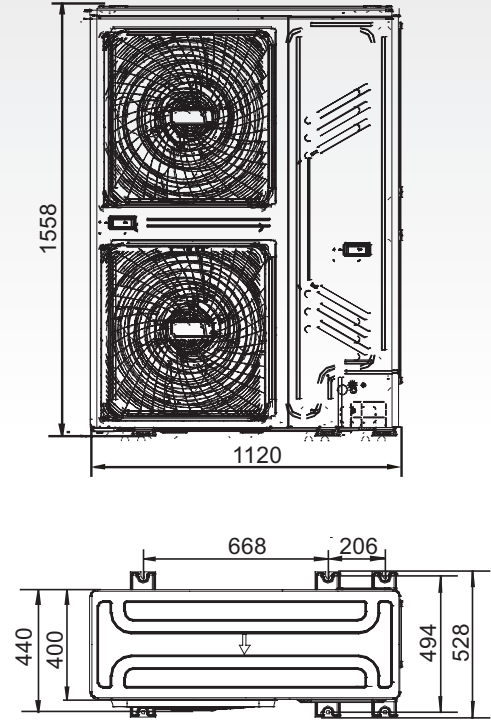
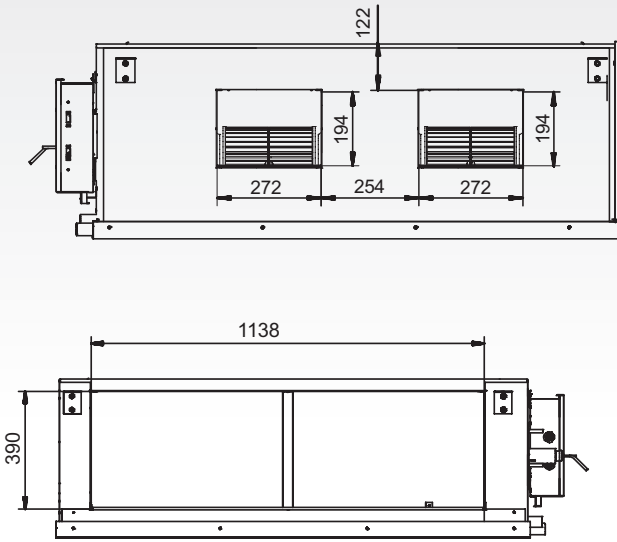

units: mm

ELECTRICAL WIRING DIAGRAM

POWER SUPPLY 380-415V ~50HZ

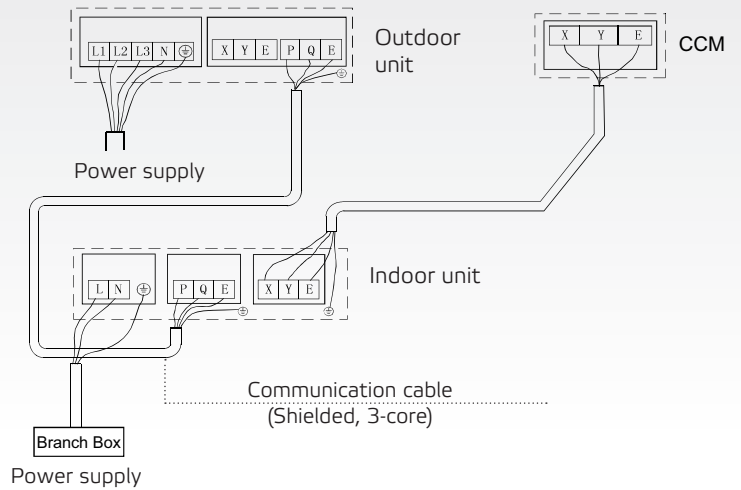
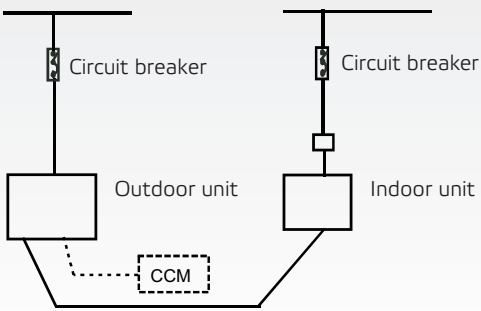

SPLIT AIR CONDITIONER

TOWER SERIES

MODEL	AST-24BI		
Capacity cooling/heating 1)	Nominal	kW	7,2 / 7,9
Power supply 1)	Frequency/Voltage	Hz / V	1~ / 50 / 220-240
Power input cooling/heating 1)		W	2050 / 2330
Maximal power input 2)		W	3900
Power current cooling/heating		A	10,0 / 11,0
Maximal power current 2)		A	18
Energy class cooling 3)		-	A++
Pdesign cooling		kW	7,2
SEER		-	6,1
Annual power consumption		kWh / annum	413
Energy class heating 3)	Average climate	-	A+
Pdesign heating	Average climate	kW	6,1
SCOP	Average climate	-	4,0
Annual power consumption	Average climate	kWh / annum	2135
Airflow of ID ID	SH/H/M/L	m ³ / h	1250 / 950 / 850 / 750
Airflow of ID OD	H	m ³ / h	3200
Sound pressure of ID 4)	SH/H/M/L	dB(A)	45 / 41 / 38 / 35
Sound pressure of OD 4)	H	dB(A)	61
Sound power of ID 4)	SH/H/M/L	dB(A)	60 / 51 / 48 / 45
Sound power of OD 4)	H	dB(A)	70
Dehumidifying volume		l / h	2,0
Refrigerant type/charge	Type / kg / t eq.CO ₂		R32 / 1,6 / 1,08
Additional refrigerant		g / m	40
Pipe diameter - liquid side 5)		inch / mm	¼ / 6,4
Pipe diameter - gas side 5)		inch / mm	¾ / 15,9
Max pipe length without additional refrigerant 6)		m	5
Maximal allowed pipe length 7)		m	25
Max. elevation/ Drop height		m	10
Dimension of ID	w x h x d	mm	507 x 1770 x 320
Dimensions of OD	w x h x d	mm	965 x 700 x 396
Package dimension of ID	w x h x d	mm	1988 x 623 x 440
Package dimensions of OD	w x h x d	mm	1029 x 458 x 750
Weight of ID	net / gross	kg	38,0 / 50,0
Weight of OD	net / gross	kg	53,5 / 58,0
Set temperature range		°C	16-30
Operating temperature range 8)	cooling	°C	-15-43
	heating	°C	-15-24

ADDITIONAL TECHNICAL INFORMATION			
Screw holes distance of OD	w x d	mm	560 x 364
Communication cable		mm ²	4 x 1,5
Recommended power cable		mm ²	3 x 4,0
Recommended air switch		A	20

EQUIPMENT			
Plasma generator	indoor		-
Wifi module			✓
Drain pump			-
Max. lift (from bottom of ID unit)		mm	-
Dry contact (ON/OFF)	outdoor		-
Alarm contact			-
Fresh air inlet			-
Throttling method			EXV
Bottom chassis heater			-
Crankcase heater			-
Bottom plugs for OD			✓
Drain pipe connector			✓

STANDARD ACCESSORIES			
Standard health filter			-
Remote controller (IR)			YAP1F4 (Wifi)
Wired controller			-

OPTIONAL ACCESSORIES			
Optional health filters			-
Wired controller			-
Central controller			-

APPEARANCE AND DIMENSIONS OF UNITS

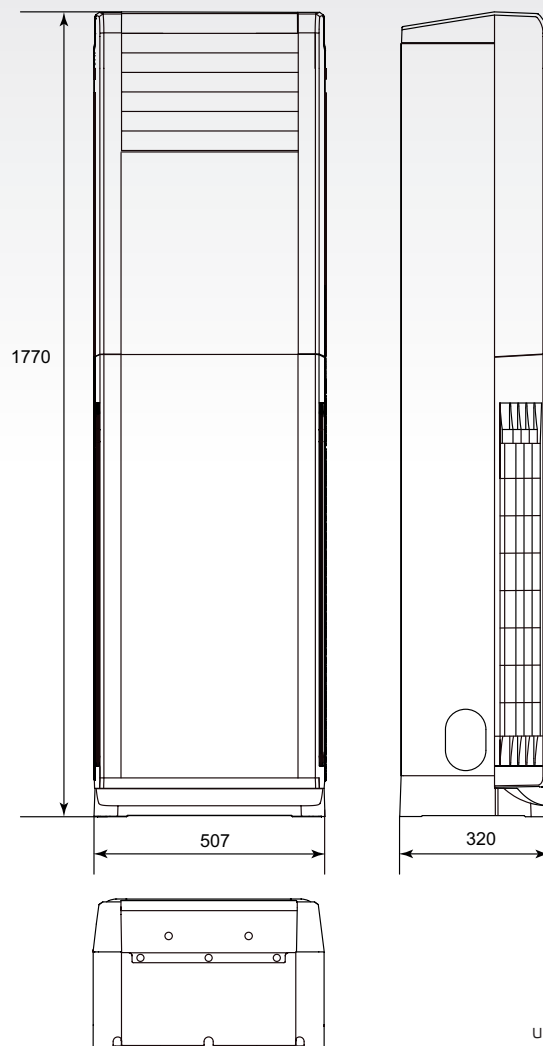

units: mm

APPEARANCE AND DIMENSIONS OF UNITS

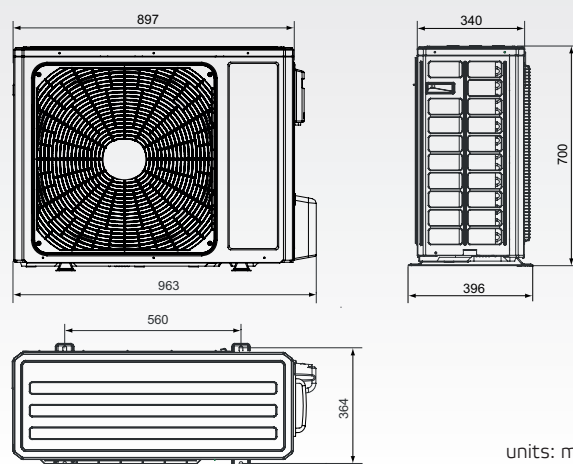

units: mm

ELECTRICAL WIRING DIAGRAM

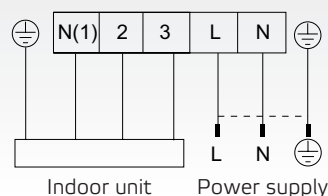

WINDOW MONOBLOCK AIR CONDITIONERS

WINDOW SERIES

MODEL			ASW-09BI	ASW-12BI		
Cooling capacity 1)	Nominal	kW	2,7	3,7		
Power supply	Frequency/Voltage	Hz / V	1~ / 50 / 220-240	1~ / 50 / 220-240		
Application area		m ²	12-18	16-24		
Power input cooling 1)		W	782	1030		
Maximal power input 2)		W	1100	1300		
Power current cooling		A	3,5	4,6		
Maximal power current 2)		A	5,5	6,5		
SEER		-	3,45	3,54		
Energy class cooling		-	A	A		
Airflow of ID	H/M/L	m ³ /h	400 / 360 / 320	480 / 430 / 380		
Airflow of OD	H	m ³ /h	800	1200		
Sound pressure of ID 4)	H/M/L	dB(A)	50 / 48 / 46	50 / 48 / 46		
Sound pressure of OD 4)	H/M/L	dB(A)	56 / 54 / 52	58 / 56 / 54		
Sound power of ID 4)	H/M/L	dB(A)	59 / 57 / 55	59 / 57 / 55		
Sound power of OD 4)	H/M/L	dB(A)	65 / 63 / 61	65 / 63 / 61		
Dehumidifying volume		l/h	1,0	1,6		
Refrigerant type/charge		Type / kg / t eq.CO ₂	R32 / 0,51 / 0,34	R32 / 0,63 / 0,43		
Dimension	w x h x d	mm	560 x 375 x 710	660 x 428 x 700		
Package dimension	w x h x d	mm	623 x 425 x 806	739 x 505 x 793		
Weight	net / gross	kg	43,0 / 47,0	50,0 / 54,0		
Set temperature range		°C	16 ~ 30	16 ~ 30		
Operating temperature range cooling 8)		°C	16 ~ 43	16 ~ 43		
STANDARD ACCESSORIES						
Standard health filter			-	-		
Remote controller (IR)			YX1F	YX1F		
Wired controller			-	-		
OPTIONAL ACCESSORIES						
Optional health filters			-	-		
Wired controller			-	-		
Central controller			-	-		

The specification of products is subject to change based on further development of the units by the producer and can be changed without prior notice. Refer to rating label.

R32 (single component refrigerant HFC), GWP of refrigerant used: 675.

Contains fluorinated greenhouse gases covered by the Kyoto Protocol.

Hermetically sealed system.

Explanatory notes on the very last page of the catalogue.

APPEARANCE AND DIMENSIONS OF UNITS

ASW-09BI

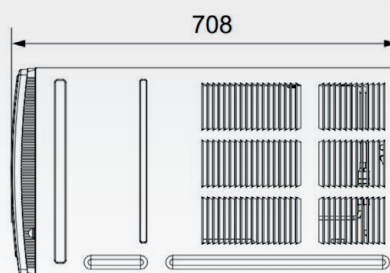
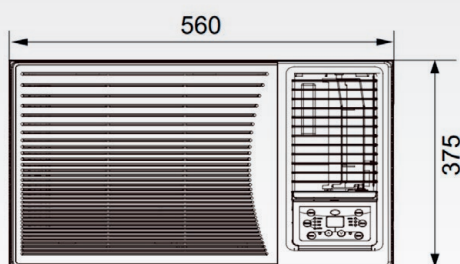

ASW-12BI

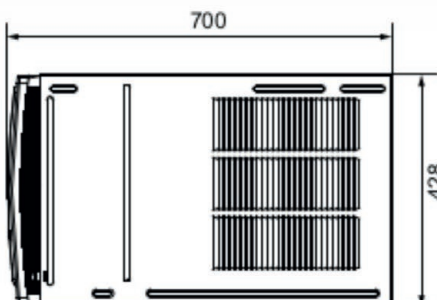
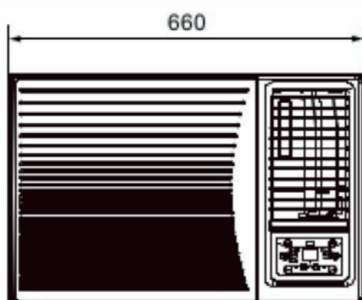

units: mm

VEHICLE AIR CONDITIONERS

CAMPER TRAILER AIR CONDITIONER

MODEL			ASV-25AS	ASV-35AS			
Capacity cooling/heating 1)	Nominal	kW	2,5 / 2,2	3,5 / 3,2			
Power supply	Frequency/Voltage	Hz / V	1~ / 50 / 220-240	1~ / 50 / 220-240			
Power input cooling/heating 1)		W	1070 / 980	1270 / 1180			
Maximal power input 2)		W	1400	1400			
Power current cooling/heating		A	4,7 / 4,2	4,7 / 4,2			
Maximal power current 2)		A	6,6	6,6			
EER / COP		-	2,34 / 2,24	2,76 / 2,71			
Airflow of ID	SH/H/M/L	m³ / h	340 / 280 / 220 / 190	380 / 320 / 260 / 230			
Airflow of OD	H/L	m³ / h	600 / 300	600 / 300			
Sound pressure of ID 4)	SH/H/M/L	dB(A)	53 / 48 / 43 / 38	55 / 49 / 44 / 39			
Sound pressure of OD 4)	H/L	dB(A)	65 / 55	65 / 55			
Sound power of ID 4)	SH/H/M/L	dB(A)	63 / 58 / 53 / 48	65 / 59 / 54 / 49			
Sound power of OD 4)	H/L	dB(A)	75 / 65	75 / 65			
Dehumidifying volume		l / h	1,0	1,5			
IP protection		-	IP x 4	IP x 4			
Roof mounting hole		mm	356 x 356	356 x 356			
Roof thickness		mm	30 - 80	30 - 80			
Refrigerant type/charge		Type / kg / t eq.CO ₂	R410A / 0,67 / 1,4	R410A / 0,67 / 1,4			
Dimension of ID	w x h x d	mm	485 x 49 x 610	485 x 49 x 610			
Dimension of OD	w x h x d	mm	1018 x 259 x 650	1018 x 259 x 650			
Package dimension of ID	w x h x d	mm	547 x 109 x 668	547 x 109 x 668			
Package dimension of OD	w x h x d	mm	1099 x 312 x 715	1099 x 312 x 715			
Weight of ID	net / gross	kg	2,7 / 4,0	2,7 / 4,0			
Weight of OD	net / gross	kg	42,5 / 49,0	42,5 / 49,0			
Set temperature range		°C	16 ~ 30	16 ~ 30			
Operating temperature range 8)	cooling	°C	18 ~ 43	18 ~ 43			
	heating	°C	2 ~ 24	2 ~ 24			
EQUIPMENT							
Plasma generator	indoor		-	-			
Wifi module			✓	✓			
Drain pump			-	-			
Max. lift (from bottom of ID unit)		mm	-	-			
Dry contact (ON/OFF)	outdoor		-	-			
Alarm contact			-	-			
Fresh air inlet			-	-			
Throttling method			Capillary	Capillary			
Bottom chassis heater			-	-			
Crankcase heater			-	-			
Bottom plugs for OD			-	-			
Drain pipe connector			-	-			
STANDARD ACCESSORIES							
Standard health filter				-	-		
Remote controller (IR)			YAM1F1	YAM1F1			
Wired controller			-	-			
OPTIONAL ACCESSORIES							
Optional health filters			-	-			
Wired controller			-	-			
Adapter			ASV-PA	ASV-PA			

The specification of products is subject to change based on further development of the units by the producer and can be changed without prior notice. Refer to rating label.

R410A (50% HFC-32, 50% HFC-125), GWP 2088

Contains fluorinated greenhouse gases covered by the Kyoto Protocol.

Hermetically sealed system.

Explanatory notes on the very last page of the catalogue.

POWER SUPPLY, APPEARANCE AND DIMENSIONS OF UNITS

Indoor unit

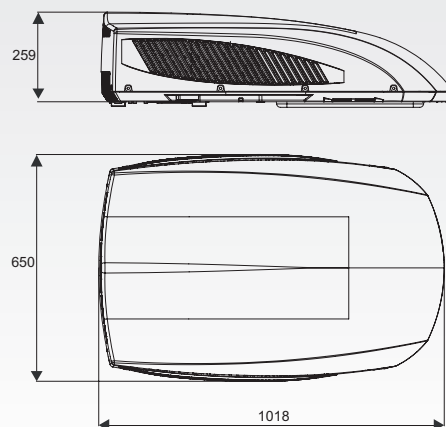
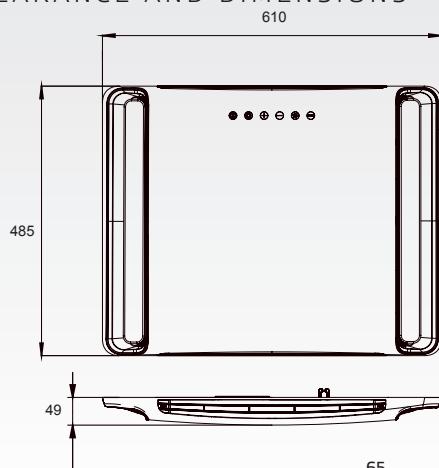
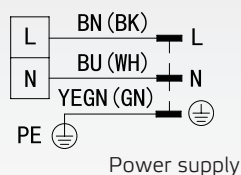

units: mm

WATER-TO-AIR HEAT PUMP

BOAT SERIES

MODEL			ASB-05A	ASB-09A	ASB-12A	ASB-16A	ASB-24A
Capacity cooling/heating 12)	Nominal	kW	1,10 / 1,40	2,10 / 2,20	3,10 / 3,20	3,20 / 4,00	6,40 / 6,65
Power supply	Frequency/Voltage	Hz / V	1~ / 50 / 220-240	1~ / 50 / 220-240	1~ / 50 / 220-240	1~ / 50 / 220-240	1~ / 50 / 220-240
Power input cooling/heating 1)		W	560 / 530	900 / 880	1100 / 1100	1200 / 1300	1450 / 1750
Maximal power input 2)		W	800 / 750	1350 / 1100	1600 / 1700	1650 / 1650	2400 / 2700
Power current cooling/heating		A	3,5 / 3,4	4,9 / 4,8	6,1 / 6,0	6,0 / 6,1	6,8 / 8,2
Maximal power current 2)		A	6,2 / 6,1	7,3 / 7,0	9,0 / 9,0	8,2 / 8,6	11,5 / 11,8
EER / COP		-	1,96 / 2,64	2,33 / 2,50	2,82 / 2,91	2,67 / 3,08	4,41 / 3,80
Airflow of ID	H	m ³ / h	320	450	466	590	951
Sound pressure of ID 4)	H	dB(A)	58	58	58	62	60
Sound power of ID 4)	H	dB(A)	68	68	68	72	70
Refrigerant type/charge		Type / kg / t ekv.CO ₂	R410A / 0,32 / 0,67	R410A / 0,34 / 0,71	R410A / 0,53 / 1,11	R410A / 0,46 / 0,96	R410A / 0,95 / 1,98
Dimension of ID	w x h x d	mm	285 x 408 x 295	380 x 408 x 310	380 x 420 x 330	450 x 465 x 330	595 x 529 x 386
Package dimension of ID	w x h x d	mm	594 x 493 x 360	683 x 513 x 360	608 x 533 x 395	663 x 558 x 395	853 x 638 x 440
Weight of ID	net / gross	kg	25,5 / 30,0	28,0 / 33,0	33,0 / 38,0	37,5 / 43,5	60,5 / 68,0
Set temperature range		°C	16~30	16~30	16~30	16~30	16~30
Operating temperature range cooling 8)		°C	16~43	16~43	16~43	16~43	16~43
Operating temperature range heating 8)		°C	-10~30	-10~30	-10~30	-10~30	-10~30
Operating temperature range cooling 8)	water	°C	10~35	10~35	10~35	10~35	10~35
Operating temperature range heating 8)	water	°C	4~25	4~25	4~25	4~25	4~25
STANDARD ACCESSORIES							
Standard health filter						-	
Remote controller (IR)						Y x 1F	
Wired controller						✓	

The specification of products is subject to change based on further development of the units by the producer and can be changed without prior notice. Refer to rating label.

R410A (50% HFC-32, 50% HFC-125), GWP 2088

Contains fluorinated greenhouse gases covered by the Kyoto Protocol.

Explanatory notes on the very last page of the catalogue.

INSTALLATION OF UNIT

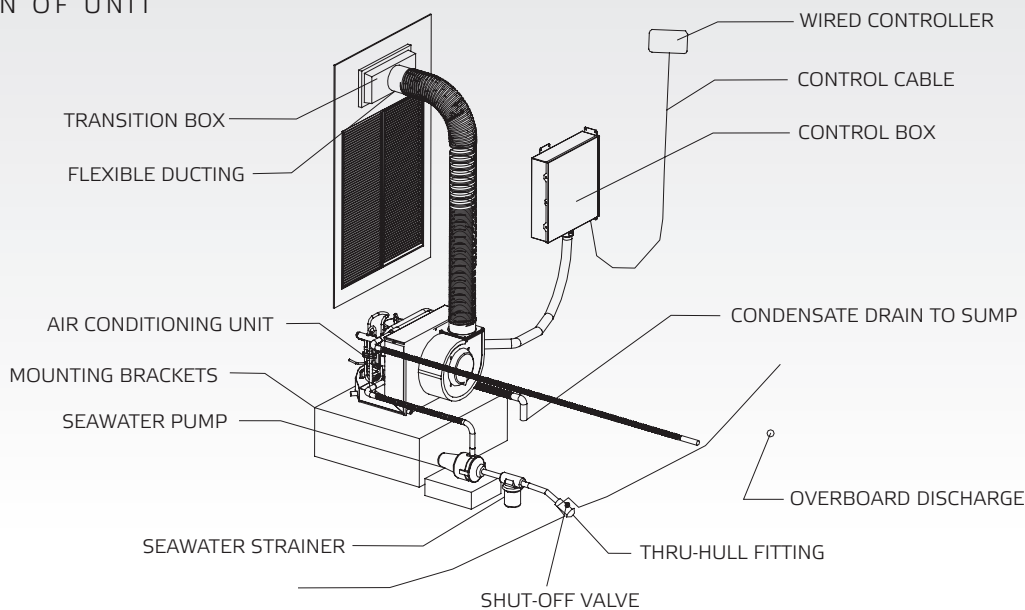

APPEARANCE, DIMENSIONS AND WIRING OF UNITS

BOAT SERIES

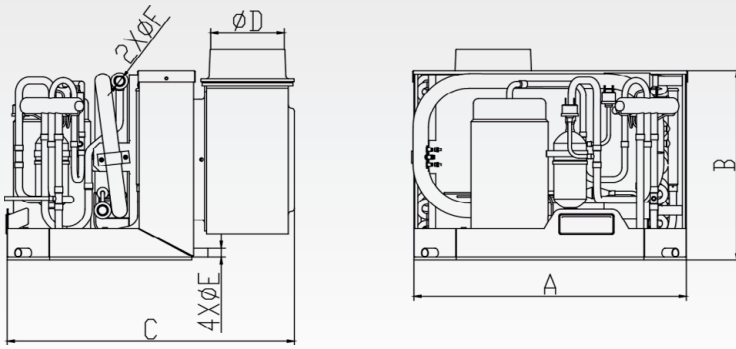

units: mm

	A	B	C	D	E	F
ASB-05A	285	295	408	91,5	16	19
ASB-09A	380	310	408	91,5	16	19
ASB-12A	380	330	420	119,4	16	19
ASB-16A	450	330	465	119,4	16	19
ASB-24A	529	386	595	119,4	16	19

ELECTRICAL WIRING DIAGRAM

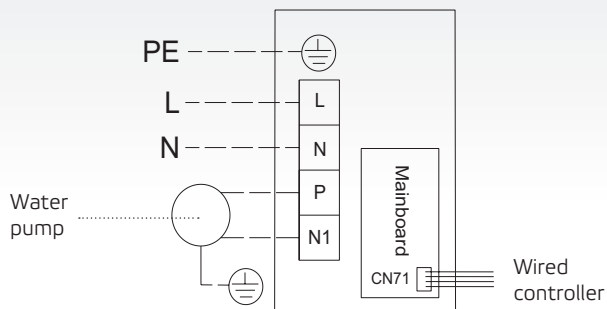

PACKAGE CONTENTS

	Package Include
Wired Controller	✓
Remote Controller	✓
Communication Cable of Wired Controller (8 m)	✓
Power Supply Wire	-
Inlet/Outlet water pipe	-
Fixed board	-
Condensing drain pipe	-
Flexible Ducting	-
Air Diffuser	-
Air Return Grill	-
Water pump	-
Filter	-

LOCAL AIR CONDITIONERS

MODEL			AMC-11P	AMC-14P		
Capacity	Cooling	kW	3,0	4,0		
	Heating	kW	3,0	4,0		
Optimal room size		m ²	15-25	25-35		
Power supply	Frequency/Voltage	Hz / V	1~ / 50 / 220-240	1~ / 50 / 220-240		
Rated current		A	5,5	6,8		
Power input	Cooling/Heating	W	1150 / 965	1535 / 1290		
EER / COP		-	2,6 / 3,1	2,6 / 3,1		
Energy class	Cooling/Heating	-	A / A++	A / A++		
Noise - indoor unit		dB(A)	65	65		
Air flow		m ³ /h	450	450		
Dehumidifying volume		l/day	50	70		
Refrigerant type/ charge		Type / kg	R290 / 0,23	R290 / 0,27		
Dimension (w x h x d)		mm	300 x 760 x 532	300 x 760 x 532		
Package dimension (w x h x d)		mm	330 x 855 x 620	330 x 855 x 620		
Net/ gross weight		kg	28,6 / 30,7	30,6 / 32,8		
Operating temperature	Cooling	°C	17-32	17-32		
	Heating	°C	7-25	7-25		

R290 (100% CH3CH2CH3)

APPEARANCE AND DIMENSIONS OF UNITS

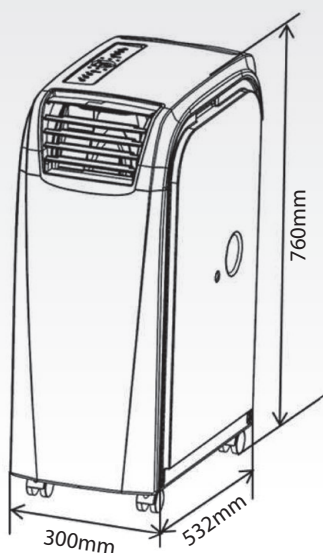

units: mm

ACCESSORIES



AMC-WINK
WINDOW KIT
(standard)

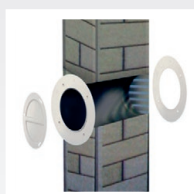

AMC-WK
WALL KIT
(optional)

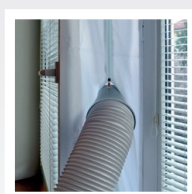

WK-400A
WINDOW KIT
(optional)

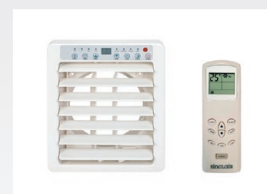

AK-15P
(optional)

MOBILE DEHUMIDIFIERS

MODEL			CFO-16P	CFO-20P	CFO-40P		
Dehumidifying volume		l/day	16,0	20,0	40,0		
Power supply		Hz / V	1~ / 50 / 220-240	1~ / 50 / 220-240	1~ / 50 / 220-240		
Power input / Max. power input		W	220 / 245	360 / 450	670 / 900		
Rated current		A	1,1	2,1	4,0		
Sound pressure level		dB	41 / 38	43 / 41 / 39	48 / 45 / 42		
Air flow		m³/h	115 / 100	130 / 115 / 105	230 / 195 / 170		
Water tank volume		l	2,5	3,5	6,5		
Optimal room size		m²	20	28	48		
Refrigerant type / charge		Type / kg	R290 / 0,085	R290 / 0,11	R290 / 0,15		
Dimension (w x h x d)		mm	305 x 490 x 192	363 x 577 x 245	396 x 625 x 286		
Package dimension (w x h x d)		mm	345 x 540 x 230	428 x 602 x 311	448 x 338 x 638		
Net/ gross weight		kg	10,5 / 11,5	15,5 / 17,0	22,5 / 24,5		
Operating temperature		°C	5 ~ 32	5 ~ 32	5 ~ 32		

R290 (100% CH3CH2CH3)

The values stated in the sheet are complying with norm EN810

Dehumidifying volume is measured according to EN60335-2-40, test conditions: DB 30%, RH 80%

APPEARANCE AND DIMENSIONS OF UNITS

CFO-16P

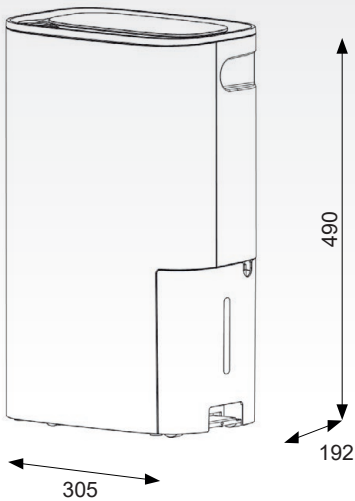

CFO-20P

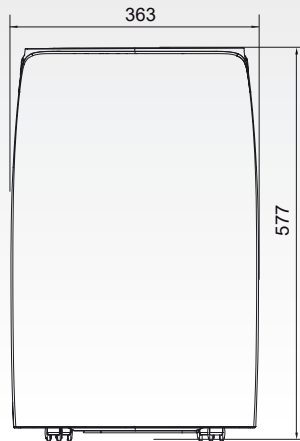

CFO-40P

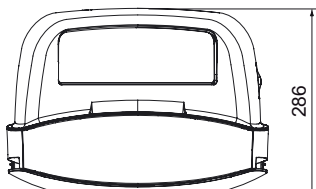
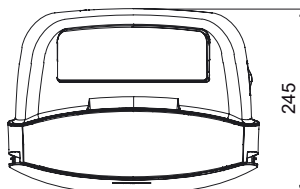
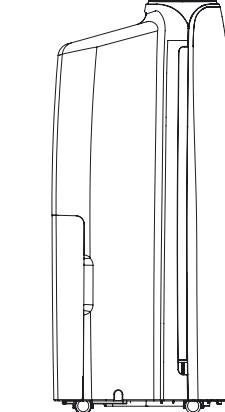
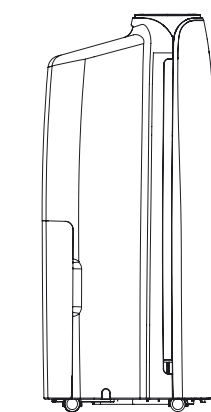
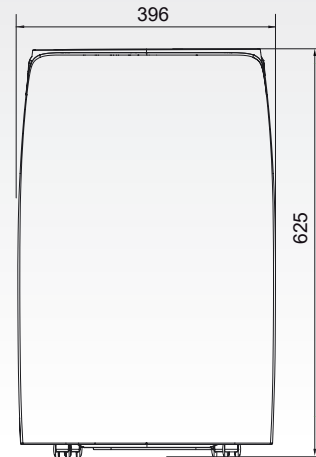

units: mm

PORTABLE DEVICE

AIR PURIFIER

MODEL			SP-45A	SP-75UV			
Power supply		Hz / V	1~ / 50 / 220-240	1~ / 50 / 220-240			
Power input		W	80	70			
Rated current		A	0,4	0,3			
Sound pressure level at 1m	min - max	dB	19 - 51	22-57			
Cleaning volume		m ³ /h	340	600			
Optimal room size		m ²	10-45	10-75			
Dimension (w x h x d)		mm	374 x 594 x 201	320 x 745 x 320			
Package dimension (w x h x d)		mm	433 x 667 x 260	378 x 853 x 378			
Net/ gross weight		kg	6,8 / 8,5	9,7 / 11,0			
Operating temperature		°C	0 ~ 40	0 ~ 40			

APPEARANCE AND DIMENSIONS OF UNITS

ACCESSORIES

SP-45A



SP-75UV



Standard:

- 1pc HEPA filter
- 1pc active carbon filter
- 1pc cotton filter

Optional:

- SPF-45: replaceable dust filters

Standard:

- filter SPF-75 (HEPA H13, active carbon filter and cotton filter)

COMMUNICATION MODULE SCMI-01.4



LOW GOAL TEMPERATURE UP TO -10°C

- SCMI-01.4 offers 3 basic operation modes:
 - Autonomous temperature control mode: The system changes its performance in order to achieve set temperature measured with T2 sensor. You can set temperature from -10 °C to +55 °C
 - Slave unit mode – operated: You set the compressor performance directly via 0-10V input. Evaporating temperature depends on compressor performance and other conditions
 - Autonomous pressure (evaporating temperature) control mode for cooling only: The compressor performance changes based on evaporating pressure. You can set the pressure which corresponds with temperatures from -10°C to +55°C.
- Control of separate condensing units of UNI SPLIT series
- Direct operation mode (cooling) or reverse operation mode (heating)
- Control of FMD modules
- Password protected setting
- Language options
- Pre-setting of all parameters via USB Communicator software
- DIN rail compatible – 4M wide, installation in power distribution unit

DEFAULT SETTINGS

Function		Operated	
Goal Temp.	C (cooling)	+10,0°C	
	H (heating)	+25,0°C	
Outputs	Relay 1	Function	On/Off
		Logic	Direct
	Relay 2	Compressor	
	Relay 3	Error	
	DC fan	Off	
Regulation	Time constant	30sec	
	Proportional constant	35	
	Integration constant	0	
	Derivation constant	60	

TECHNICAL PARAMETERS

Power supply	V/Hz	230 / 50 ±10%
Rated power input	VA	15
Dimension (wxhxd)	mm	90x71x58
Package dimension (wxhxd)	mm	120x100x80
Net/gross weight	kg	0,21 / 0,35
Storage temperature	°C	-25 ~ +70
Operating temperature	°C	-10 ~ +55
Outputs	3x output relays 230/2V	
Inputs	communication input	
	2x input for temperature sensors; input for FMD modules (VE+, VE-)	
	1x voltage input 0-10V, resistance 100kΩ	
	1x current input for pressure sensor 0-18bar	
Standard accessories	2x temperature sensor NTC015WF00 (10kΩ; B=3435)	
Optional accessories	Pressure sensor Alco Controls PT5-18M	

CONDENSING UNITS ASGE-XXBI, ASGE-XXBI-3

- Automatic protection of outdoor unit
- Automatic defrost of outdoor unit
- Informational error display placed on the main board.
- EC fan motor
- Electronic expansion valve as standard accessory
- Connection valves and terminal block on right side
- Compressor heater as standard accessory
- Bottom heater as optional accessory



AUTONOMOUS TEMPERATURE CONTROL MODE FOR COOLING AND HEATING

Performance of the outdoor unit compressor is controlled to keep the temperature set for cooling/heating/ mode combi. The room temperature is measured with the resistance thermometer T2. It is necessary to set the requested temperature for cooling and heating manually. Use "21" and "22" non-potential contacts for switching between cooling and heating mode.

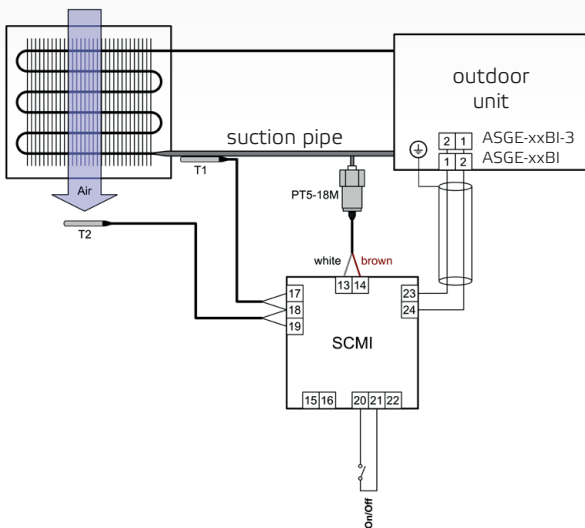

SLAVE UNIT MODE - OPERATED

Performance of the outdoor unit compressor is controlled with SCMI-01.4 module according to direct voltage 0-10V from an external supply. The voltage value corresponds with the desired compressor performance 0-100%. The unit can work in both modes – cooling and heating, H/C connectors are used for switching the modes.

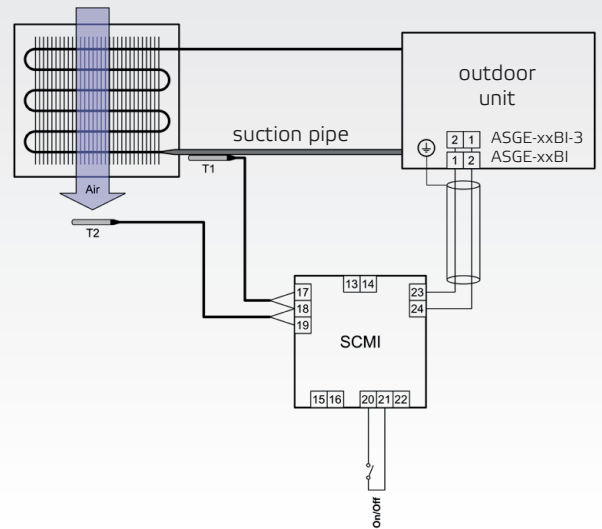

AUTONOMOUS PRESSURE (EVAPORATION TEMPERATURE) CONTROL FOR COOLING

Performance of the outdoor unit compressor is controlled to keep the requested cooling temperature recalculated to appropriate refrigerant (R32) pressure.

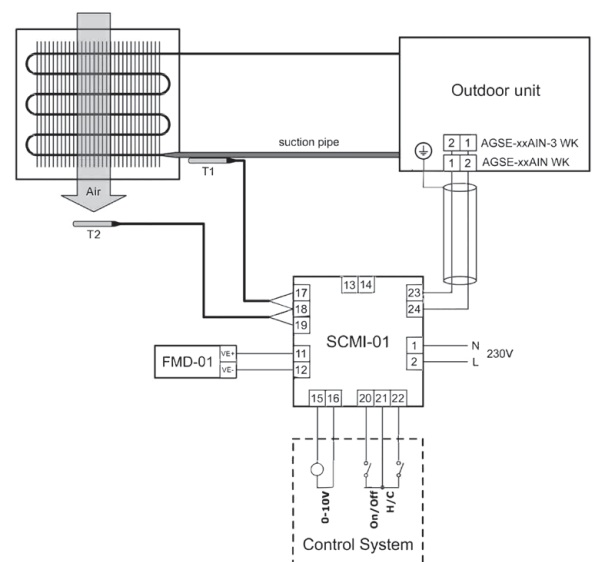
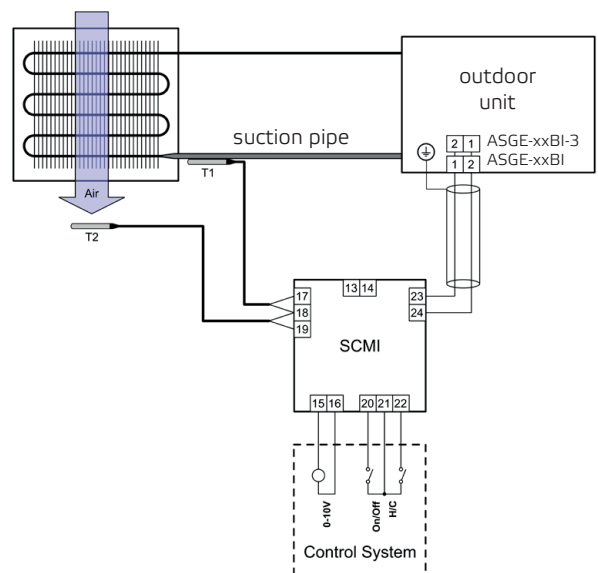

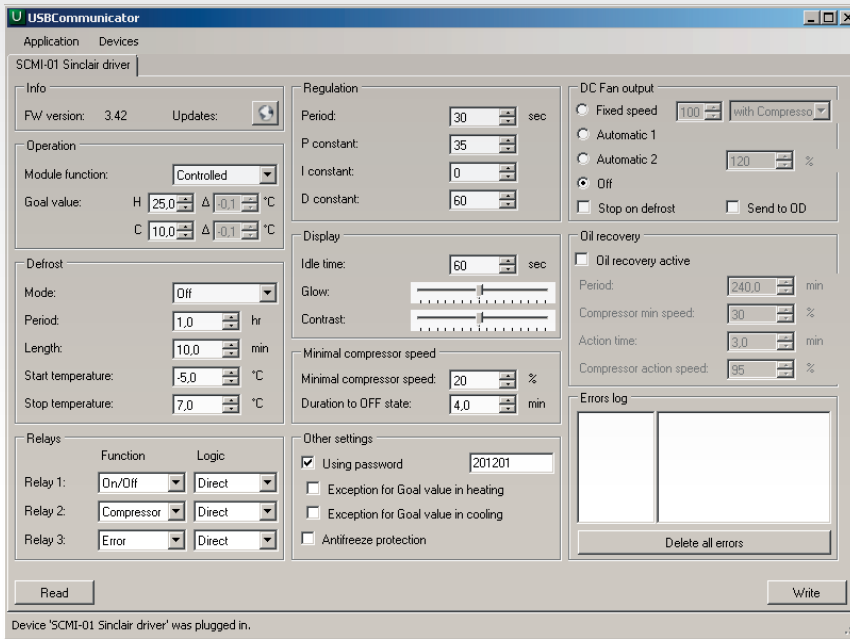

SOFTWARE FOR SCMI-01.4 CONTROL

- Distant setting
- Quick summary of all settings
- Language options (EN, DE, PL, CZ, HU, HR)
- Password setting
- View of error history, history eraser

FMD MODULES

FMD modules are used to control speed of DC fan motors.

FMD-01

Designed to control fan motors of indoor units from UNI SPLIT series*. The fan speed is controlled via SCMI-01.4 module.

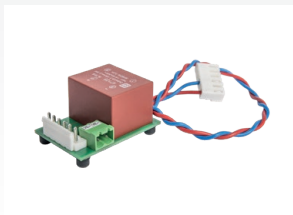

* ASD-xxBI, ASC-xxBI, ASF-xxBI except ASD-48BI, ASD-60BI

FMD-01T

Designed to control fan motors of indoor units from UNI SPLIT series*. The fan speed is controlled via multi-turn trimmer.



OTHER FUNTIONS

SELF-DIAGNOSIS

- Stopping the system when failure has been detected
- Error code displaying on SCMI-01.4
- Automatic defrost

HEALTH FILTERS FOR WALL MOUNTED UNITS

SAF-OPWC4

CATECHIN FILTER

Catechin is a green tea extract added to the filters for its oxidizing and sterilizing effects. Active enzymes form a benzene nucleus which absorbs odors and harmful substances in the air. Catechin filter effectively captures and sterilizes dust particles. It is antibacterial and destroys more than 95% of bacteria, e.g., Staphylococcus aureus.

SAF-OPWA4

ACTIVE CARBON FILTER

Active carbon is an excellent absorbent with capability of dual absorption: physical and chemical, as from air and from fluids. Quickly absorbs harmful gases, e.g. benzene, formaldehyde and ammonia.

SAF-OPWB4

BIOLOGICAL FILTER

This filter is made of a material with excellent properties of sterilizing and capture of dust. When air flows through the filter, dust and bacteria are retained on the filter surface, which is bio-bactericidal. In case of attachment of microbes, bio-bactericidal surface disrupts its metabolism and limits its growth. Efficiency of capturing of Escherichia coli and Staphylococcus aureus is higher than 95%.

SAF-OPWS4

SILVER ION FILTER

Silver ion filter is an entirely new kind of powerful sterilizing product. Silver ions are odorless and colorless and have no side effects, such as irritation, pollution or volatility. After sterilization the ions recycle themselves, therefore have a long lifespan and effectively prevent bacterial growth. The filter is also environmentally friendly and completely safe. It is highly efficient and destroys over 99% of the bacteria. Silver ions themselves attract bacteria and microorganisms, pass through the cell membrane and inhibit the cleavage activity of the bacteria. Disrupts DNA structure of bacteria and microorganisms, causing a loss of reproductive ability of bacteria.

SAF-OPWP4

PHOTOCATALYST FILTER

Photocatalytic filter reduces odors and germs via its ultraviolet light. Effectively purifies the air and keeps it fresh. Titan TiO₂ contained in this filter has a strong photocatalytic effect, but it is also environmentally friendly. Removes from the air more than 90% of acetic acid, formaldehyde, ammonia and more than 70% of renewable pollutants.

SAF-OPWK4

COLD CATALYST FILTER

The basic material of the filter are polyurethane (PU) and various catalytic fibers. Effectively captures and removes formaldehyde and other volatile organic compounds (VOCs), as well as harmful gases and odors. The catalyst filter can remove up to 92,9% of formaldehyde from the air within 2,5 hours.

SAF-OPWM4

ANTI-MITE FILTER

Using this filter, you can quickly remove up to 90% of the dust mites from the air. This filter is especially useful for people suffering from allergies and asthma.

WIRED CONTROLLERS



XK19

WIRED CONTROLLER

Standard accessory for duct, cassette and floor-ceiling MULTI VARIABLE units. Optionally can be connected to the indoor units of MULTI VARIABLE, FOCUS, FOCUS PLUS, SPECTRUM, SPECTRUM PLUS, SPLIT CONSOLE series.

It is necessary to order communication cable SC-H01 or SC-CDF for this controller when ordered separately.

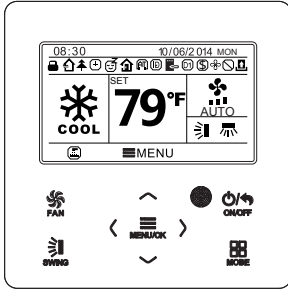

SWC-02

WIRED CONTROLLER

Optional wired controller with weekly timer for the indoor units of MULTI VARIABLE, FOCUS, FOCUS PLUS, SPECTRUM, SPECTRUM PLUS, SPLIT CONSOLE series.

It is necessary to order communication cable SC-H01 or SC-CDF for this controller.



SC-H01

Cable for connection of split wall mounted units or MULTI VARIABLE wall mounted, console units or split CONSOLE units with wired controllers XK19 or SWC-02. Length of cable is about 8 meters.



SC-CDF

Cable for connection of MULTI VARIABLE cassette, duct or floor-ceiling indoor units with wired controllers XK19 or SWC-02. Length of cable is about 8 meters.

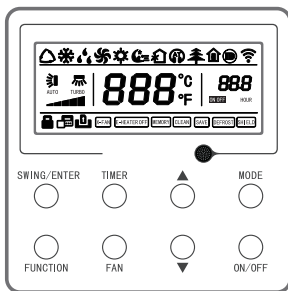

XK117

WIRED CONTROLLER

Standard accessory for indoor units of UNI SPLIT series.

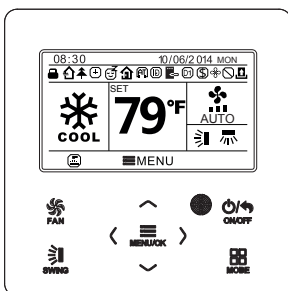

SWC-03

WIRED CONTROLLER

Optional wired controller with weekly timer to the indoor units of UNI SPLIT series.

TECHNICAL PARAMETERS

WIRED CONTROLLERS

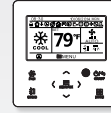
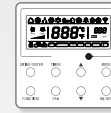
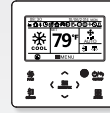

Model	XK19	SWC-02	XK117	SWC-03
On/Off	✓	✓	✓	✓
Mode selection	✓	✓	✓	✓
Temperature setting	✓	✓	✓	✓
Fan control	✓	✓	✓	✓
Swing louver	✓	✓	✓	✓
Save function setting	✓	✓	✓	✓
Room temperature display	✓	✓	✓	✓
Buttons lock	✓	✓	✓	✓
Function lock	✓	✓	✓	✓
On/Off timer	✓	✓	✓	✓
Daily timer	-	✓	-	✓
Weekly schedule timer	-	✓	-	✓
Two week schedule timer	-	✓	-	✓
Auto restart	✓	✓	✓	✓
Turbo mode	✓	✓	✓	✓
Blow (X-fan) mode	✓	✓	✓	✓
Quiet function	-	✓	-	✓
Sleep curve setting	✓	✓	✓	✓
Clock display	-	✓	-	✓
Remote signal receiver	✓	-	✓	-
Clean filter reminder	-	✓	-	✓
Error check function	✓	✓	✓	✓
Unit parameters view	-	✓	-	✓
°F / °C display	-	✓	-	✓
Slave/master controller setting	-	-	✓	-
8°C heating mode	-	-	✓	✓
Low temperature drying mode (12°C)	-	-	✓	✓
Forced defrost mode	✓	✓	✓	✓
Setting (debugging) menu:	Error code history	✓	✓	✓
	Address setting for central controlling	✓	✓	✓
	Ambient temperature sensor setting	✓	✓	✓
	Fans speed level setting	✓	✓	✓
	Antifreeze protection of evaporator (E2) display	-	✓	✓
	Refrigerant leakage protection display	-	✓	✓
	Blow function setting	-	-	✓
	Crankcase heater setting	-	-	✓
	Stand-by power consumption setting	-	-	✓
	On/Off contact activation	-	✓	✓
	External device setting	-	-	✓
	Fan speed setting	-	-	✓
	Temperature compensation setting	-	✓	✓
	AUTO mode selection	-	-	✓
	Defrost mode selection	-	-	✓
Heat pump enabled	✓	-	✓	
Connection	SC-H01 / SC-CDF	SC-H01 / SC-CDF	2-core wire	2-core wire
Dimension	w x h x d	86 x 98 x 39	112 x 112 x 22	86 x 98 x 39
				112 x 112 x 22

CENTRAL CONTROLLERS

SCC-16



CENTRAL CONTROLLER AND WEEKLY TIMER

This central controller allows you to control up to 16 unit simultaneously and set the weekly timer.

It can be used with UNI SPLIT series (has to be connected via modbus gateway SMG-01 – each indoor unit needs to have one SMG-01) or when connected via wired controller SWC-02 or XK19 and communication cable SCC-16k it can be used with MULTI VARIABLE series, R32 wall mounted split units or split CONSOLE series (each indoor unit needs to have one SWC-02 or XK19 and N + 1 pcs of communication cables SCC-16k, where N is number of indoor units).

SCC-16K



COMMUNICATION CABLE FOR SCC-16 CENTRAL CONTROLLER

Used to connect the indoor units to SCC-16 central controller

Necessary number of cables = number of indoor units + 1 pc (if connected to MULTI VARIABLE or R32 wall mounted or split CONSOLE) or 1pc (when connected to UNI SPLIT series).

CONNECTING SCHEMAS

Central controller SCC-16 with UNI SPLIT series

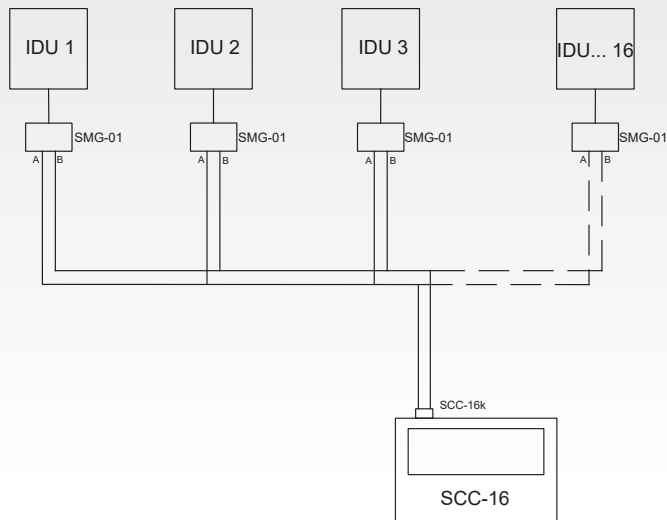

Central controller SCC-16 with multi variable, R32 wall mounted or split console series

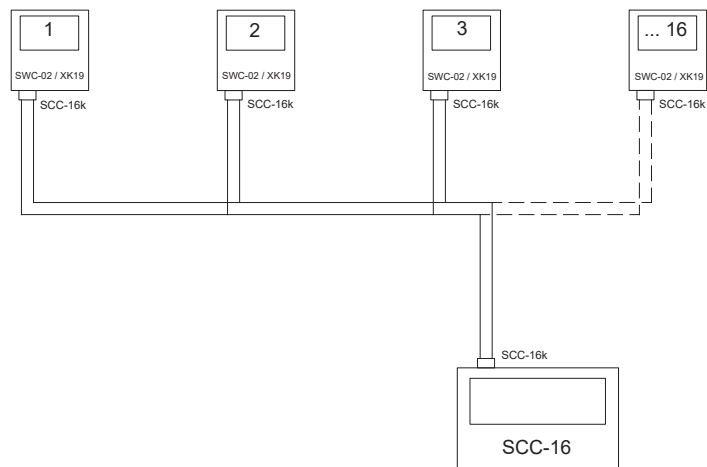

CENTRAL CONTROLLERS

SCC-36

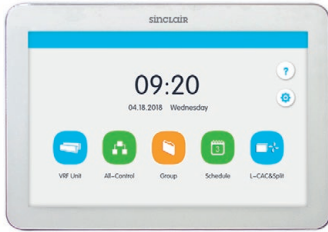

CENTRAL CONTROLLER AND WEEKLY TIMER

- Stylish central controller with 7" touch screen
- Connects up to 36 indoor units
- User friendly interface
- Weekly timer
- Single, group or all units control

It can be used with UNI SPLIT series (has to be connected via Modbus gateway SMG-01 – each indoor unit has to have one SMG-01) or when connected via wired controller SWC-02 and communication cable SCC-36k it can be used with MULTI VARIABLE series, R32 wall mounted split units or split CONSOLE series (each indoor unit has to have one SWC-02 and two SCC-36k).

SCC-36K



COMMUNICATION CABLE FOR CENTRAL CONTROLLER SCC-36

Used for connection of indoor units with central controller SCC-36 and wired controller SWC-02 (for MULTI VARIABLE series, R32 wall mounted units or split Console series).

Order in amount $2N-1$ where N is number of indoor units.

CONNECTING SCHEMAS

Central controller SCC-36 with UNI SPLIT series

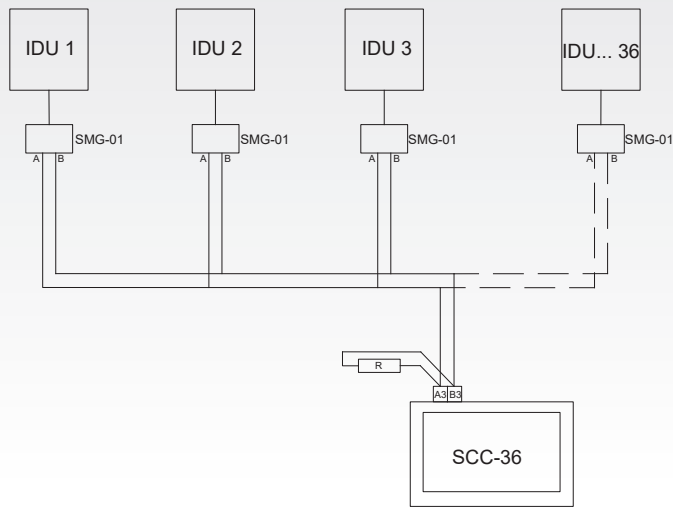

Central controller SCC-36 with multi variable, R32 wall mounted or split console series

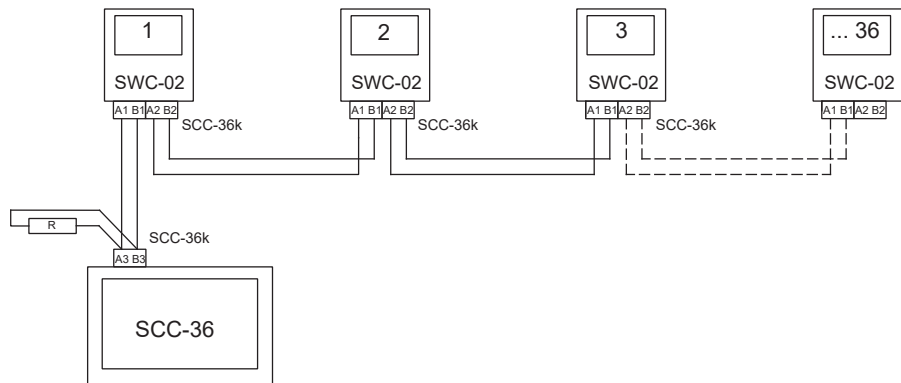

OTHER ACCESSORIES

SBG-01



BACNET GATEWAY

Bacnet gateway allows external control via Bacnet protocol. One gateway can communicate with up to 255 indoor units. The connection is done via SWC-02 or SMG-01, so the gateway is compatible with UNI SPLIT series and with all indoor units that allow connection of SWC-02 wired controller.

SCMI-03S



CONTROL MODULE

Control module for Air Conditioners in Server Rooms

- For 2 air conditioners in the same room
- Periodic switching of the units
- Turning on the 2nd unit when there is lack of capacity
- Error signalization when limit temperature is exceeded

SWM-03



SINCLAIR MODUL GSM

WIFI module can be connected to indoor unit to achieve long distance control with smart phone or tablet. SWM-03 is optional accessory for UNI SPLIT units.

SMG-01



SINCLAIR DRY CONTACT GATEWAY

Enables communication of indoor units of UNI SPLIT series via the Modbus protocol. It can be used for connecting SCC-36 central controller or for connection of external control system using Modbus protocol. Control software is not included, it has to be field supplied.

G2S



GSM CONTROL MODULE

G2S module is used for control of SINCLAIR air-conditioners via your mobile phone (via GSM). It applies IR transfer for communication with the air-conditioner, therefore there is no need to connect it to the air-conditioner in any way. By this means it operates as another remote controller. The module is equipped with two transmitting IR diodes, signaling diodes, slot for SIM card insertion and with connectors for connection of power supply cable and for the USB port of a computer.

SDG-01



SINCLAIR DRY CONTACT GATEWAY

Dry contact gateway allows to externally turn the unit on or off and switch its modes. Module is also equipped with more functions like signalizing of malfunction, etc.

OTHER ACCESSORIES

G2S-T



GSM MODULE FOR TEMPERATURE MONITORING

G2S-T module is used for remote monitoring of room temperature. When the set temperature is exceeded, the module sends an information to user's mobile phone. Hence the module has to be equipped with a mini SIM card in order to secure the operation. G2S-T is a stand-alone device, there is no connection between the module and the air conditioner itself. Therefore you can use our G2S-T module for all kinds of applications involving installations with devices of other brands.

SAI-01



ALARM INTERFACE

The SAI-01 SINCLAIR Alarm Interface is an external, separately powered module, which can be connected to the communication line of wall-mounted air conditioner to indicate the operational or malfunction status of the A/C.

SYSTEM ERROR DIAGNOSTICS

SDT-ASH

DIAGNOSTIC TOOL FOR SPLIT WALL MOUNTED AC

- Indoor and outdoor unit diagnostic
- Running parameters
- Simulation run of indoor or outdoor unit
- Test of indoor and outdoor mainboard during communication malfunction
- IR receiver (can be used during outdoor unit's test run)
- User friendly (just 4 buttons)
- Simple display (4 lines)
- No need for other accessories
- Connected to terminal board of units

SDT-MV

DIAGNOSTIC TOOL FOR MULTI SPLIT AC

- Compatible with Multi Variable, Multi System and High Power Multi System series
- Automatic detection of connected units
- User friendly interface
- Running parameters of whole system
- Connected to outdoor unit's mainboard
- 3 diodes (power supply, running, error)
- Power supply: USB connector (cable is included in the package, 5V adapter is field supplied)





TECHHELP

SINCLAIR TECHHELP APP

- This practical tool is used for identification of error codes and their brief analysis.
- List of our products and their error codes, brief description of each error and suggested solution together with possible causes.
- Search comfortably by error code or device name
- Save the already installed devices between "My Devices" and have relevant information about errors available immediately



The app is available at below mentioned web page. Login is required, please use following user name and password. Installing of an application requires permission to install applications from unknown sources.

EN	User name: SinclairTechHelp.en	
	Password: TechHelp1	
DE	User name: SinclairTechHelp.de	
	Password: TechHelp1	
HU	User name: SinclairTechHelp.hu	
	Password: TechHelp1	
PL	User name: SinclairTechHelp.pl	
	Password: TechHelp1	



For downloading of Sinclair tech Help application use the App Store and the following password:

EN	Password: 100285	

GENERAL OVERVIEW OF ERROR CODES

APPLIES TO WALL MOUNTED SPLIT UNITS AND TO MULTI VARIABLE SERIES

ERROR		Others	
E0	Start-up protection to adjust the frequency when the power input is low	AL	X-fan
E1	High pressure protection	C5	Malfunction of jumper cap
E2	Freeze protection	C6	Ground wire missing
E3	Low pressure protection, refrigerant lacking protection	CC	Wrong wired controller/locked buttons
E4	Compressor high discharge temperature protection	CP	Protection from cold air blowing
E5	Overcurrent protection of the complete unit	EE	Malfunction of outdoor main control memory chip
E6	Communication malfunction	ee	Malfunction of outdoor drive module memory chip
E7	Mode conflict	EU	Limit/decrease frequency due to module temperature protection
E8	High temperature protection	H0	Decrease frequency for high temperature resistant in heating mode
E9	Full water protection	H1	Defrosting
Failure		H2	Electrostatic dedust protection
F0	Refrigerant lacking protection	H3	Overload protection of compressor
F1	Indoor ambient temperature sensor is open/short circuited	H4	Overload protection
F2	Indoor evaporator temperature sensor is open/short circuited	H5	IPM protection (module current protection)
F3	Outdoor ambient temperature sensor is open/short circuited	H6	Malfunction of indoor fan motor
F4	Outdoor condenser temperature sensor is open/short circuited	H7	Desynchronizing of compressor
F5	Outdoor discharge temperature sensor is open/short circuited	H8	Water overflow protection
F7	Oil return cycle	Hc	PFC protection
F8	Limit/decrease frequency due to current protection of the complete unit	HE	Demagnetizing protection of compressor
F9	Decrease frequency due to high air discharge	Hp	Evaporator temperature is higher than 58°C (heating mode)
FA	Limit/decrease frequency due to high evaporator or condenser temperature	JF	Malfunction of Wi-Fi module
FH	Limit/decrease frequency due to freeze protection	L3	Malfunction of ODU DC fan motor
Fo	Gathering refrigerant	Lp	Indoor unit and outdoor unit do not match
Protection		U1	Malfunction of phase current circuit detection for compressor
P0	Drive module reset protection	Ld	Compressor phase lack protection
P5	Overcurrent protection of compressor	U3	Malfunction of voltage dropping of DC bus-bar
P6	Communication malfunction between main control and drive	U4	Compressor is reversing
P7	Malfunction of module temperature sensor circuit	U5	Malfunction of complete unit's current detection
P8	Module high temperature protection	U6	High temperature protection of oil
P9	Zero-crossing protection	U7	The 4-way valve is abnormal
PL	Voltage of DC bus-bar is too low		
PH	Voltage of DC bus-bar is too high		
PU	Charging malfunction of capacitor		
PP	Input voltage is abnormal		

* Does not apply to UNI SPLIT SERIES

GENERAL OVERVIEW OF ERROR CODES

E1	Phase sequence error	P0	Top high temperature protection of inverter compressor
E2	Indoor & outdoor unit communication error	P1	High pressure protection or high temperature protection of discharge sensor
E4	Ambient temperature T4/pipe temperature T3 sensor error	P2	Low pressure protection
E5	Voltage error	P3	Outdoor input current protection
E6	DC fan motor fault	P4	Compressor discharge temperature protection
E7	Discharge sensor error	P5	Pipe temperature protection
EA	A fan in the A region run for more than 5 minutes in HEAT mode	P6	Inverter module protection
Eb	2 times of E6 protection in 10 minutes	P8	Storm protection
E8	Outdoor unit address is wrong	PE	Evaporator high temperature protection
E9	EEPROM error	P9	DC fan module protection
H0	IR341 and main control chip communication error	L0	Inverter module error
H1	Communication chip and main control chip communication error	L1	DC generatrix low voltage error
H4	Three times P6 protection in 60 minutes	L2	DC generatrix high voltage error
H5	Three times P2 protection in 60 minutes	L4	MCE error/ synchronization/ closed loop
H6	Three times P4 protection in 100 minutes	L5	Zero speed protection
H7	The number of indoor units decreases	L7	Phase sequence error
H8	High pressure sensor error	L8	Frequency protection - frequency difference in one second more than 15Hz
H9	Three times P9 protection in 60 minutes	L9	Frequency protection - frequency difference between the real and the setting frequency more than 15Hz
HF	M-HOME for the indoor and outdoor units does not match		

GENERAL OVERVIEW OF ERROR CODES

Module SCMI-01.4 error	
Error T1 open	Open circuit of temperature sensor T1
Error T2 open	Open circuit of temperature sensor T2
Error T1 short	Short circuit of temperature sensor T1
Error T2 short	Short circuit of temperature sensor T2
Error P open	Open circuit of pressure sensor P
Error P short	Short circuit of pressure sensor P
Error P low	Low pressure on suction side of compressor
Err. com disconnected	Communication malfunction between SCMI-01.4 module and outdoor unit
Error of UNI SPLIT series outdoor unit	
01000000	E4 - Compressor discharge high-temperature protection
02000000	Lack of refrigerant protection
04000000	Fan DC motor protection
08000000	4-way valve protection
10000000	Overcurrent protection
20000000	H3 - Overload protection
40000000	E3 - Compressor low pressure protection
80000000	E1 - Compressor high pressure protection
00010000	Indoor unit freezing protection
00020000	F3 - Indoor unit freezing protection
00040000	F4 - Discharge temperature sensor malfunction
00080000	F2 - Condenser temperature sensor malfunction
00100000	Condenser inlet tube temperature sensor malfunction
00200000	C5 - Invalid power code (invalid position of the jumper)
00400000	Drive unit memory chip malfunction
00000100	Protection against starting compressor at a low frequency at a low voltage
00000200	DC Bus overvoltage protection
00000400	AC current protection
00000800	IPM protection
00001000	PFC protection
00002000	Start up malfunction
00004000	Compressor wrong phase order protection
00008000	Drive unit module sensor malfunction
00000001	Compressor overcurrent protection
00000002	Power supply protection
00000004	Circuit current measurement malfunction
00000008	H7 - Compressor desynchronization protection
00000010	Compressor stalling protection
00000040	Drive unit module high-temperature protection
00000080	Drive unit module sensor malfunction

EXPLANATORY NOTES:

- Data are based on following conditions: Length of connection pipe: 5m. Cooling: indoor temperature 27°C DB/19°C WB, outdoor temperature 35°C DB/24°C WB. Heating condition: indoor temperature 20°C DB/15°C WB, outdoor temperature 7°C DB/6°C WB.
- Data are based on following conditions: Length of connection pipe: 5m. Cooling: indoor temperature 27°C DB/19°C WB, outdoor temperature 35°C DB/24°C WB. Heating condition: indoor temperature 20°C DB/15°C WB, outdoor temperature 7°C DB/6°C WB.
- SEER/SCOP was calculated according to European standards contained in EN14825, based on part load classifying and testing conditions given by norm EN14511. Energy label can be downloaded from Sinclair product web page after B2B login.
- Noise is tested in the semi-anechoic room, so it should be slightly higher in the actual Operation due to environmental change.
- Cooling mode
- Standard length of liquid pipes pre-filled with refrigerant.
- Maximum length of liquid pipes in one-way including elevation between indoor and outdoor unit.
- Guaranteed range of operational temperatures.
- Maximum length of liquid pipes to last indoor unit.
- EER/COP in accordance with EN14511.
- If the outdoor unit is power supplied, the cable between indoor unit and outdoor unit is also common for communication.
- Data are based on following conditions: Cooling: indoor temperature 27°C DB/19°C WB, water temperature 25°C, water temperature slope 5°C, pressure 0Pa; Heating: indoor temperature 20°C DB/15°C WB, water temperature 15°C, water flow same as for cooling, pressure 0Pa.

SH/MH/H/M/L/ML/SL	super high / mid high / high / mid / low / mid low / super low
EXV	electromagnetic expansion valve
R32	(100% HFC-32), GWP 675.
R290	(100% CH ₃ CH ₂ CH ₃), GWP 3
R410A	(50% HFC-32, 50% HFC-125), GWP 2088
R134A	(100% HFC-134a), GWP 1300
R290	(100% CH ₃ CH ₂ CH ₃), GWP 3
ID/OD	indoor unit/outdoor unit

This catalogue is informative only and does not constitute a binding offer from the side of SINCLAIR CORPORATION LTD. The Company takes no responsibility for any damage arising out of using or interpretation of this catalogue. The noise levels mentioned in this catalogue are values measured under ideal conditions, in an anechoic chamber. These values can be influenced by local conditions (acoustical bouncing area, the equipment of the room, etc.). The specification of products is subject to change based on further development of the units by the producer and can be changed without prior notice. The reproduction of information or data, in particular the use of texts, text excerpts or images, requires the prior written approval of the company. The contents of this catalogue is protected by copyright of SINCLAIR CORPORATION LTD.

